

Steel TIPS

STRUCTURAL STEEL EDUCATIONAL COUNCIL



TECHNICAL INFORMATION & PRODUCT SERVICE

December 2006

Seismic Detailing of Gusset Plates for Special Centrally Braced Frames

By

Abolhassan Astaneh-Asl, Ph.D., P.E.,

Professor

Department of Civil and Env. Engineering, and
Center for Catastrophic Risk Management
University of California, Berkeley

Michael L. Cochran, S.E.

Vice President

Brian L. Cochran Associates, Inc.
Consulting Structural Engineers, Los Angeles

And

Rafael Sabelli, S.E.

Principal, Director of Technical Development

DASSE Design Inc.

Structural Engineers

San Francisco and Oakland

Copyright © 2006 by Abolhassan Astaneh-Asl, Michael L. Cochran, and Rafael Sabelli,
All rights reserved.

Seismic Detailing of Gusset Plates for Special Concentrically Braced Frames

By Abolhassan Astaneh-Asl, Michael L. Cochran, and Rafael Sabelli

Summary

This Steel Technical Information and Product Services (Steel TIPS) report focuses on providing information to steel fabricators, detailers, and structural engineers on detailing gusset plates in special concentrically braced frames (SCBFs). Current seismic design requirements (AISC 2005c) for special concentrically braced frames permit braces that buckle out of the plane of the gusset to be designed with pinned ends if a detail can be provided that allows for the end rotation that is expected from the buckling of the brace. Tests by Astaneh-Asl, Goel, and Hanson (1982) using hinge-zone lengths of zero, t , $2t$, and $4t$ showed that the length of $2t$ is sufficient to accommodate the expected cyclic rotation of the end of the bracing member as it undergoes cyclic buckling. Note that the parameter t is the thickness of the gusset plate. The specimens with hinge-zone length of less than $2t$ did not perform in a sufficiently ductile manner to be qualified for use in special concentrically braced frames. Satisfying this requirement in design offices or fabricating shops can be an iterative and sometimes a time-consuming process. The main goal of this report is to provide assistance in this regard by presenting simple and closed-form equations that can be used in detailing the gusset plate without a need for iterations. The equations that are given in this report can be programmed into a spreadsheet to calculate the dimensions of the gusset plate automatically. One such spreadsheet has been developed by the first author, A. Astaneh-Asl, and is offered by the Engineering & Publishing Services (EPS) at its web site <http://www.ENG PUB.com>.

In addition, this Steel TIPS report provides a number of suggested details for special concentrically braced frame gusset plates that can assist design professionals as well as steel fabricators and erectors in proper and economical detailing. Appendix A provides suggestions for improved details. Appendix B provides information on gusset-plate detailing when the beam is sloped, and Appendix C is on gusset plates at the base of columns.

First Printing, December 2006

Text content copyright © 2006 Abolhassan Astaneh-Asl, Michael L. Cochran, and Rafael Sabelli. All rights reserved. Drawings and photos by and copyright © 2006 Abolhassan Astaneh-Asl. All rights reserved.

No parts of this publication can be reproduced in any form or included in other documents without the written permission of the copyright holders. Permission is granted to the Structural Steel Educational Council to post a PDF version of this publication on its web site, <http://www.steeltips.org>.

Authors:

Abolhassan Astaneh-Asl, Ph.D., P.E., Professor, University of California, Berkeley
E-mail: Hassan@Astaneh.net, Web: <http://www.Astaneh.net>

Michael L. Cochran, S.E., Vice President,
Brian L. Cochran Associates, Inc., Consulting Structural Engineers, Los Angeles

Rafael Sabelli, S.E., Principal, Director of Technical Development
DASSE Design Inc. Structural Engineers, San Francisco and Oakland

Acknowledgments

Funding for this publication was provided in part by the California Iron Workers Administrative Trust. The publication of this report was made possible through partial support of the Structural Steel Educational Council (SSEC). The authors wish to thank all SSEC members, particularly Fred Boettler, SSEC administrator, James J. Putkey, Patrick M. Hassett, Fred Breismeister, and Jeffrey Eandi (current chair of the SSEC), for their technical input and review comments. Special thanks are due to Jeffrey Eandi for suggesting the need for information in the steel fabricating shops on the subject of this Steel TIPS.

Dave Berrens of Strocacal Inc., Steve Richardson of W & W Steel Company, William A. Thornton of Cives Steel Company, and Jamie Winans of Reno Iron Works provided very valuable comments on the detailing of gusset plates. The authors appreciate their time and input.

The opinions expressed in this publication are solely those of the authors and do not necessarily reflect the views of the University of California, Berkeley, Brian L. Cochran Associates, Inc., and DASSE Design Inc., where, respectively, the authors are employed. In addition, the opinions expressed here do not necessarily reflect the views of the Structural Steel Educational Council or other agencies and individuals whose names appear in this report.

Disclaimer: The information presented in this publication has been prepared in accordance with recognized engineering principles and is for general information only. While it is believed to be accurate, this information should not be used or relied upon for any specific application without competent professional examination and verification of its accuracy, suitability, and applicability by a licensed professional engineer, designer, or architect. The publication of the material contained herein is not intended as a representation or warranty on the part of the Structural Steel Educational Council, or of any other person named herein, that this information is suitable for any general or particular use or of freedom from infringement of any patent or patents. Anyone making use of this information assumes all liability arising from such use.

Caution must be exercised when relying upon specifications and codes developed by others and incorporated by reference herein since such material may be modified or amended from time to time subsequent to the printing of this document. The Structural Steel Educational Council or the authors bear no responsibility for such material other than to refer to it and incorporate it by reference at the time of the initial publication of this document.

Seismic Detailing of Gusset Plates for Special Concentrically Braced Frames

By:

ABOLHASSAN ASTANEH-ASL, Ph.D., P.E., Professor
University of California, Berkeley

MICHAEL L. COCHRAN, S.E., Vice President
Brian L. Cochran Associates, Inc., Consulting Structural Engineers, Los Angeles

RAFAEL SABELLI, S.E., Principal, Director of Technical Development,
DASSE Design Inc., Structural Engineers, San Francisco and Oakland

TABLE OF CONTENTS

ACKNOWLEDGMENTS / Page 2

DISCLAIMER / Page 2

TABLE OF CONTENTS / Page 3

NOTATIONS / Page 4

CHAPTER 1. CURRENT SEISMIC CODE 2¹ HINGE-ZONE REQUIREMENT IN GUSSET PLATES / Page 6

CHAPTER 2. SEISMIC DETAILING OF GUSSET PLATES / Page 10

CHAPTER 3. SUGGESTED GUSSET-PLATE DETAILS FOR SCBFs / Page 29

REFERENCES / Page 37

APPENDIX A: OTHER GUSSET-PLATE DETAILS FOR SCBFs / Page 39

APPENDIX B: GUSSET PLATES WITH SLOPED BEAMS / Page 42

APPENDIX C: GUSSET PLATES AT THE BASE OF COLUMNS / Page 50

ABOUT THE AUTHORS / Page 53

LIST OF PUBLISHED STEEL TIPS REPORTS / Page 54

PARTICIPATING MEMBERS OF SSEC / Back Cover

Notations

- A = Dimension of vertical side of gusset plate (shown in Figure 2.1)
- A_g = Gross area of bracing member
- B = Dimension of horizontal side of gusset plate (shown in Figure 2.1)
- C = For cases where the gusset plate is connected to the flange of the column, C is the horizontal distance from the “work point” to the column flange connected to the gusset plate as shown in Figures 2.7, 2.8, and 2.9. For double symmetric columns, C would be half the column depth. For cases where the gusset plate is connected to the web of the column (see Figure 3.4), parameter C is the horizontal distance from the work point to the tip of the gusset plate stiffener.
- C_1 = Vertical dimension measured from the intersection of the beam and column centerlines to the intersection of the line of restraint at the column flange and the column centerline (shown in Figure 2.10)
- C_2 = Vertical dimension measured from the intersection of the beam and column centerlines to the intersection of the line of restraint at the beam flange and the column centerline (shown in Figure 2.10)
- CJP = abbreviation for Complete Joint Penetration
- D = Vertical distance from the work point to the beam flange connected to the gusset plate as shown in Figures 2.7, 2.8, and 2.9. For double symmetric beams, D is equal to half the depth of the beam.
- F = Distance from the center line of a sloped beam to the flange that is connected to the gusset plate (used in Appendix B)
-
- F_y = Specified minimum yield stress of the bracing member material
- F_{ypl} = Specified minimum yield stress of the gusset-plate material
- L_1 = Side dimension of the gusset plate (shown in Figure 2.1)
- L_2 = Side dimension of the gusset plate (shown in Figure 2.1)
- L_3 = Side dimension of the gusset plate (shown in Figure 2.1)
- L_4 = Side dimension of the gusset plate (shown in Figure 2.1)
- L_5 = Side dimension of the gusset plate (shown in Figure 2.1)
- L_6 = Side dimension of the gusset plate (shown in Figure 2.1)
- L_7 = Side dimension of the gusset plate (shown in Appendix B for gusset plates connected to sloped beams)
- L_b = Length of the bracing member on the gusset plate (shown in Figure 2.2)
- L_B = Length of the bolted connection, the center-to-center distance of the first and last bolts (shown in Figure 2.5b)
- L_{bc} = Length of the bolted connection of the bracing member to the gusset plate (shown in Figure 2.5b)
- L_{gph} = Length of the gusset-plate hinge zone (shown in Figure 2.2)
- L_W = Length of the weld connecting the bracing member to the gusset plate (shown in Figures 2.2 and 2.5a)

- M_p = Plastic moment capacity of the brace member with respect to its axis of buckling equal to $F_y Z_{ba}$
- R_y = Ratio of the expected yield stress to the specified minimum yield stress, F_y . R_y values for various steel are given in Table I-6-1 of the Seismic Provisions (AISC 2005c).
- $R_y F_y$ = Expected yield stress of the bracing member
- T_r = Maximum required tensile strength for connection design given in Section 13 of the AISC Seismic Provisions (AISC 2005c), as the lesser of the following:
 - The expected yield strength, in tension, of the bracing member, determined as $R_y F_y A_g$ (LRFD) and $R_y F_y A_g / 1.5$ (ASD), as appropriate
 - The maximum *load effect*, indicated by analysis that can be transferred to the brace by the system.
- U = Nonrepresentational quantity calculated to identify the first line of restraint (see Equation 2.9)
- W = Width of the gusset plate at the end of the brace (measured perpendicular to the brace axis; see Figure 2.3)
- W_1 = Portion of the width of the gusset plate at the end of the brace (measured perpendicular to the brace axis) corresponding to angle α_1 (shown in Figure 2.6)
- W_2 = Portion of the width of the gusset plate at the end of the brace (measured perpendicular to the brace axis) corresponding to angle α_2 (shown in Figure 2.6)
- W_{prl} = Width of the gusset-plate restraint line = $W_{p1} + W_{p2}$ (shown in Figure 2.6)
- W_{p1} = Width of the gusset-plate restraint line corresponding to angle α_1 (shown in Figure 2.6)
- W_{p2} = Width of the gusset-plate restraint line corresponding to angle α_2 (shown in Figure 2.6)
- $W_{Whitmore}$ = Width of the gusset plate at the end of the brace established using Whitmore's method (shown in Figure 2.3)
- Z_{ba} = Plastic section modulus of the cross-section of the bracing member with respect to the governing axis of buckling
- a = Distance from the face of the bracing to the edge of the gusset plate (shown in Figure 2.6)
- b = Width of the bracing member on the gusset plate (shown in Figure 2.6)
- t = Thickness of the gusset plate
- α_1 = Angle of the gusset edge to the brace axis (shown in Figure 2.6)
- α_2 = Angle of the gusset edge to the brace axis (shown in Figure 2.6)
- γ = Angle between the axis of the sloped beam and the horizontal line (used in Appendix B).
- θ = Angle between the axis of the bracing and the axis of the horizontal beam (shown in Figure 2.6)
- ϕ_y = Resistance factor for yielding of gross area in LRFD = 0.90

1. CURRENT SEISMIC CODE $2t$ HINGE ZONE REQUIREMENT IN GUSSET PLATES



1.1. Introduction

Currently, seismic design codes such as the AISC Seismic Provisions (AISC 2005c) have provisions regarding design of braced frame gusset plates in seismic regions. Figure 1.1 shows excerpts from the AISC Seismic Provisions (AISC 2005c) that are relevant to the gusset-plate $2t$ hinge zone. The “User Note” in Figure 1.1 refers to the gusset-plate “line of restraint” and “ $2t$ offset” in the AISC Seismic Provisions Commentary as shown in the sketch in Figure 1.1. It should be mentioned that the excerpts in Figure 1.1 are for information only, and for actual design, the AISC Seismic Provisions (AISC 2005c) should be used. According to Section 13.3b of the AISC Seismic Provisions (see Figure 1.1), the bracing connection should have a bending strength equal to or greater than $1.1R_yM_p$ in the Load and Resistance Factor Design (LRFD)

13.3. Required Strength of Bracing Connections

13.3a. Required Tensile Strength
 The *required tensile strength* of bracing connections (including beam-to-column connections if part of the bracing system) shall be the lesser of the following:

- (a) The *expected yield strength*, in tension, of the bracing member, determined as $R_yF_yA_g$ (LRFD) or $R_yF_yA_g/1.5$ (ASD), as appropriate.
- (b) The maximum *load effect*, indicated by analysis that can be transferred to the brace by the system.

13.3b. Required Flexural Strength
 The *required flexural strength* of bracing connections shall be equal to $1.1R_yM_p$ (LRFD) or $(1.1/1.5)R_yM_p$ (ASD), as appropriate, of the brace about the critical buckling axis.

Exception: Brace connections that meet the requirements of Section 13.3a and can accommodate the inelastic rotations associated with brace post-buckling deformations need not meet this requirement.

User Note: Accommodation of inelastic rotation is typically accomplished by means of a single gusset plate with the brace terminating before the line of restraint. The detailing requirements for such a connection are described in the commentary.

Seismic Provisions for Structural Steel Buildings, March 9, 2005, incl. Supplement No. 1
 Copyright © 2005 AMERICAN INSTITUTE OF STEEL CONSTRUCTION, INC. All rights reserved.

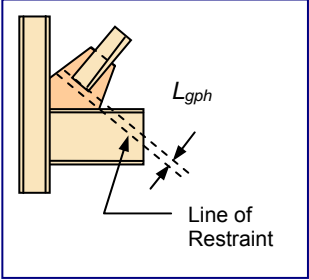
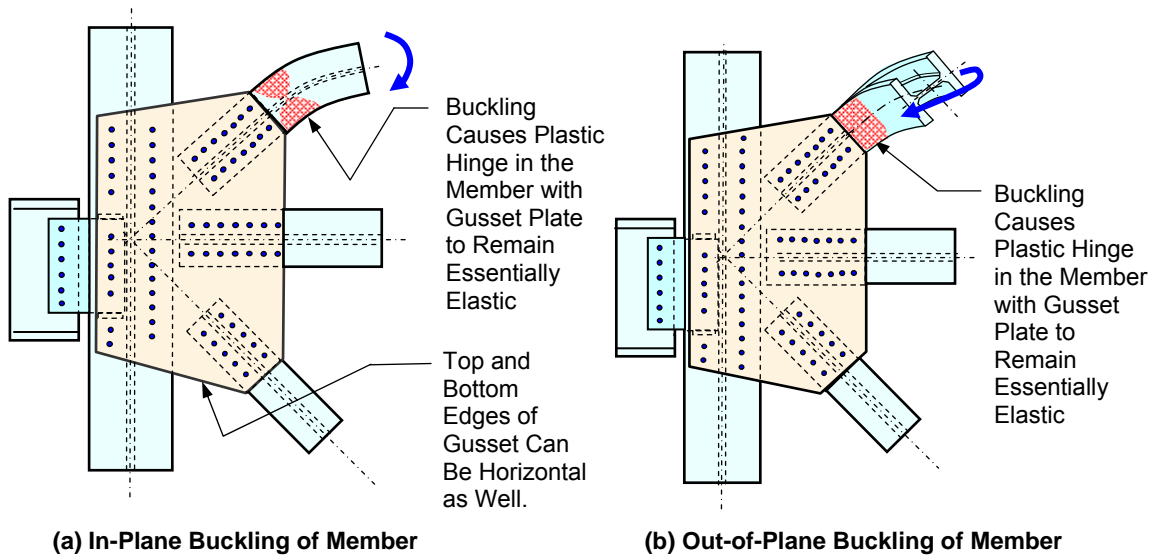

Figure 1.1. Excerpts from the AISC Seismic Provisions (AISC 2005c) Relevant to the $2t$ Requirement

method and $(1.1/1.5)R_yM_p$ in the Allowable Stress Design (ASD) method where R_y is given in Table I-6-1 of the AISC Seismic Provisions (AISC 2005c) and M_p is the plastic moment capacity of the bracing member with respect to the governing buckling axis. The provisions in Section 13.3b can be satisfied easily for a double gusset-plate connection, such as those shown in Figure 1.2 for the case of a bolted gusset connection with bracing members being wide flange sections. For hollow steel sections (HSS), similar double gusset-plate connections can be used, but the HSS section needs to be field-welded to the gusset plates.

For in-plane buckling, Figure 1.2(a), and out-of-plane buckling, Figure 1.2(b), of the bracing member, the relatively large in-plane and out-of-plane strength and stiffness of the double gussets will force yielding into the bracing member with the gusset plates remaining essentially elastic. Double gusset-plate connections have been used for more than a century and continue to be used frequently in concentrically braced frames of bridge towers, as shown in Figure 1.3, as well as in various trusses in buildings and bridges.



Graphics: Copyright © 2006 Abolhassan Astaneh-Asl. All rights reserved.

Figure 1.2. Double Gusset-Plate Connections



Photos by and © 1997, A. Astaneh-Asl. All rights reserved.

Figure 1.3. Double Gusset-Plate Connections of Carquinez Bridge Braced Frame Towers, Northern California

For single gusset-plate connections, the selection of the brace member type (that is, wide flange, pipe, rectangular HSS, double angles, and so on) and brace member orientation (that is, the strong axis of the cross-section being in or out of the plane of the frame) will influence the direction of brace member buckling. If the critical buckling axis of the brace member lies in the plane of the frame, as shown in Figure 1.4(a), the gusset plate can easily provide an in-plane plastic moment capacity greater than the above-mentioned required values of $1.1R_yM_p$ in LRFD and $(1.1/1.5)R_yM_p$ in ASD. However, the most common case in braced-frame design today is for the critical buckling axis of the selected brace member (that is, the weak axis) to be in the plane of the frame, as shown in Figure 1.4(b), resulting in out-of-plane buckling of the brace.

When the brace buckles out of the plane of the frame, its end rotations force the gusset plate to bend out of plane, as illustrated in Figure 1.4(b). In almost all such cases, the out-of-plane bending capacity of the single gusset plate will not be sufficient to satisfy the above requirement. For these cases, the “Exception” in Section 13.3b in Figure 1.1 can be used. The “Exception” given in Section 13.3b and the “User Note” below it in Figure 1.1 are based on the tests and recommendations of Astanteh-Asl, Goel, and Hanson (1982, 1983, and 1985), who studied seismic behavior of gusset plates as part of a larger research program on concentrically braced frames and recommended for gusset-plate design the use of a minimum $2t$ hinge-zone length beyond the end of the bracing member to the line of restraint to accommodate end rotations of the buckled brace member (where t is the thickness of the gusset plate).

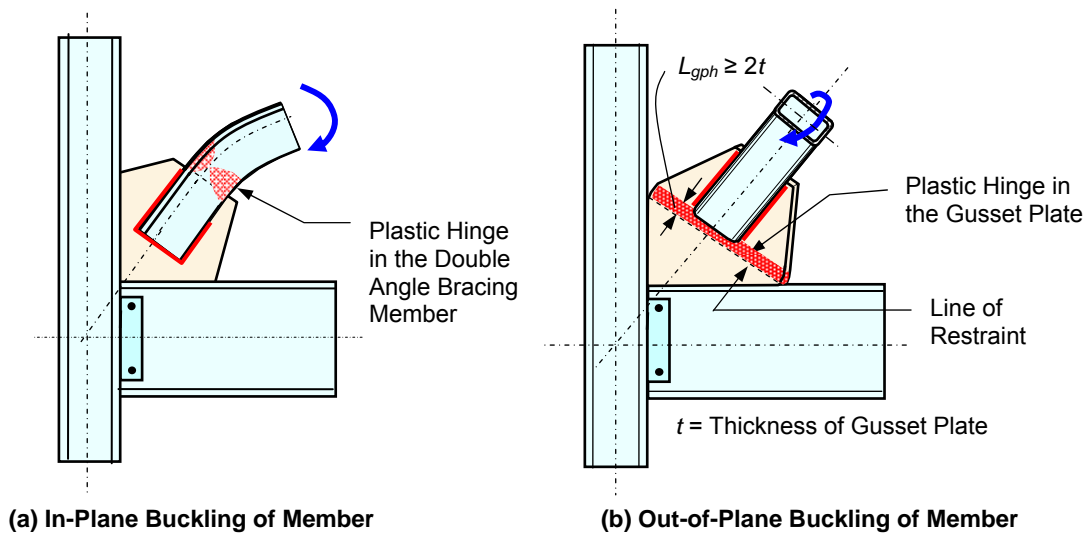

Graphics: Copyright © 2006 Abolhassan Astanteh-Asl. All rights reserved.

Figure 1.4. Single Gusset-Plate Connections

In the research program by Astanteh-Asl, Goel, and Hanson (1982), a total of eighteen specimens, which included specimens of gusset plates with zero, t , $2t$, and $4t$ hinge-zone lengths, were tested. It was observed that gusset plates with $2t$ and $4t$ hinge-zone lengths were very ductile and their cyclic behavior desirable, and these gusset plates easily qualify to be part of a

special concentrically braced frame. Therefore, in gusset-plate design, a minimum hinge-zone length of $2t$ measured from the end of the brace member to the line of restraint was recommended by Astaneh-Asl, Goel, and Hanson (1982). A maximum hinge-zone length equal to $4t$ was also suggested by the researchers as an upper limit for single-gusset brace connections buckling out of plane of the gusset plate. While the ability to form a hinge is not affected by increasing the hinge length, designers should be mindful of the overall length of the gusset plate and should verify that buckling of the gusset plate will not occur prior to buckling of the bracing member. Also, attention should be paid to the possibility of rigid-body buckling of the brace member if the hinge-zone length in the gusset plate is longer than $4t$. Rigid-body buckling of a brace occurs when two hinges form in one gusset plate, due to the long free length of the gusset plate between restraint points, and one hinge forms in the other gusset plate. The formation of three hinges results in a buckling mechanism, while the brace itself stays elastic and rotates as a rigid body; see Figure 1.5(b).

A Steel TIPS report on gusset plates by Astaneh-Asl (1998) provides more information on various aspects of seismic behavior and design of gusset plates including the $2t$ hinge-zone length.

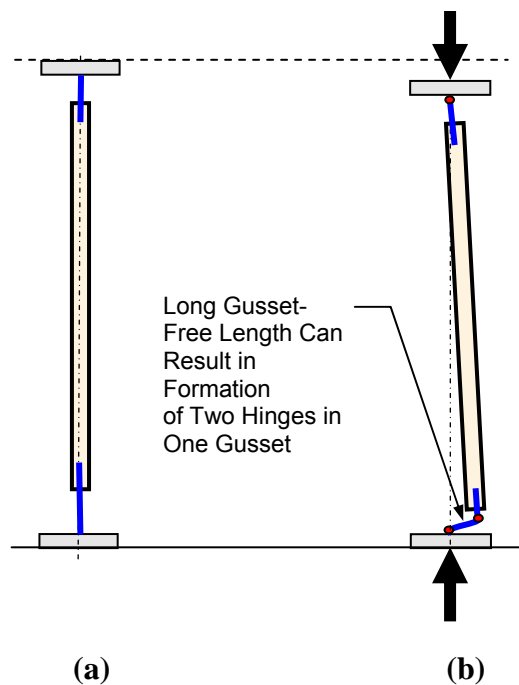
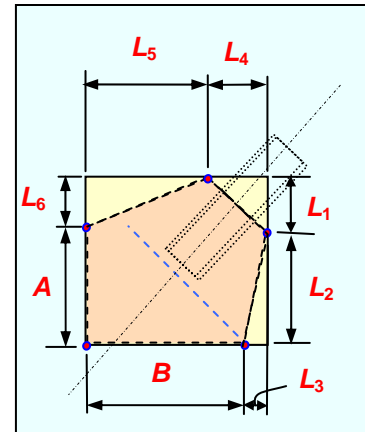

Figure 1.5. (a) A Brace Member with a Long Gusset; and (b) Buckling of the Gusset Resulting in Rigid-Body Buckling of the Brace Member

2. SEISMIC DETAILING OF GUSSET PLATES



2.1. Introduction

This chapter provides equations that can be used for layout and detailing of gusset plates at the beam/column/brace connection. The information is specifically for gusset plates in special concentrically braced frames where a minimum of $2t$ hinge-zone length is required beyond the end of the bracing member, as occurs when the brace buckles out of plane of a single gusset plate. Figure 2.1(a) shows a typical gusset plate in a concentrically braced frame, where the bracing is buckling out of plane of the frame, with a minimum hinge-zone distance $L_{gph} = 2t$ between the end of the bracing member and the line of restraint that occurs at the first reentrant corner of the gusset. The angle between the centerlines of the bracing member and the horizontal beam is θ .

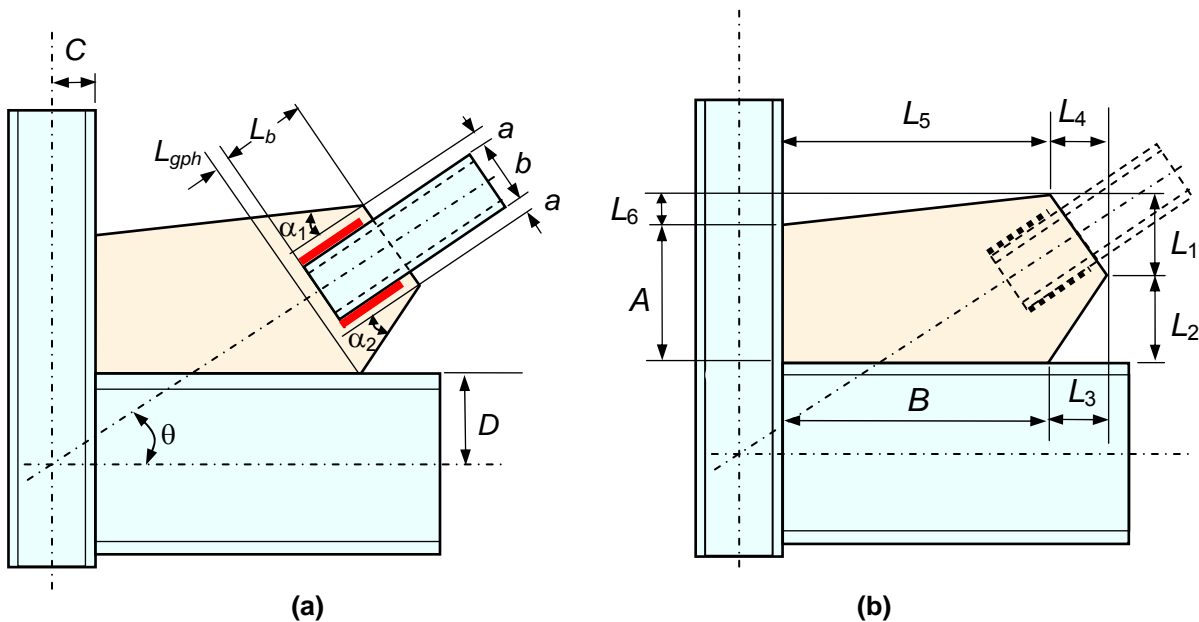
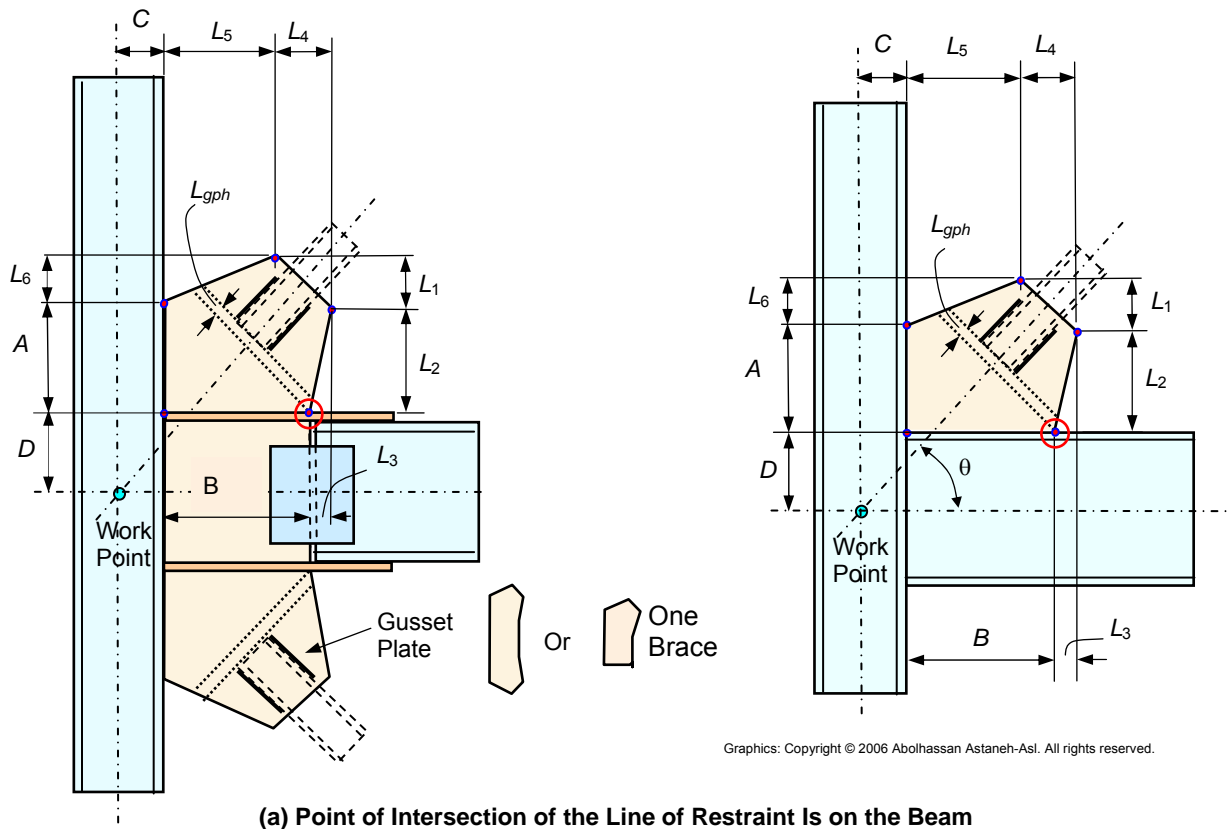

Figure 2.1. (a) Parameters Needed to Calculate the Gusset-Plate Dimensions
(b) Gusset-Plate Dimensions Needed for Gusset-Plate Detailing

There are eight edge dimensions for a gusset plate as shown in Figure 2.1(b). These dimensions, given as A , B , and L_1 through L_6 , can be obtained from the equations presented in this chapter in terms of the geometry of the connection (that is, in terms of dimensions a , b , C , D , t , L_b , and L_{gph} and angles θ , α_1 , and α_2 in Figure 2.1[a]) and used for easy layout of the gusset plate.

Figures 2.2(a) and 2.2(b) show gusset plates in which the plastic-hinge-zone line of restraint at the reentrant corner, indicated by the circle, intersects the beam and the column, respectively. Figure 2.2(c) shows a special case in which the gusset plastic-hinge-zone line of restraint intersects both the beam and the column. Figure 2.2(d), 2.2(e) and 2.2(f) show gusset plates for chevron bracing configurations. Figure 2.2(g) shows a gusset plate detail for X-brace joint at the mid-span. Later in this chapter, equations for calculating the eight gusset plate edge dimensions are given for each of the three cases in Figures 2.2(a) through 2.2(g). For cases with sloped beam and gusset plates at the base of columns, see Appendices B and C respectively.

The equations given in this chapter are meant to be used for cases where θ , the angle between the axes of the brace and the beam, is from 30 degrees to 60 degrees. Brace angles smaller than 30 degrees and larger than 60 degrees are not economical and can result in relatively large gusset plates. In such cases, the engineer should look into changing the configuration of the bracing system such that the angle θ remains within the range of 30 to 60 degrees.



Graphics: Copyright © 2006 Abolhassan Astaneh-Asl. All rights reserved.

Figure 2.2. Dimensions A , B , and L_1 to L_6 for Gusset Plates (*continued on next page*)

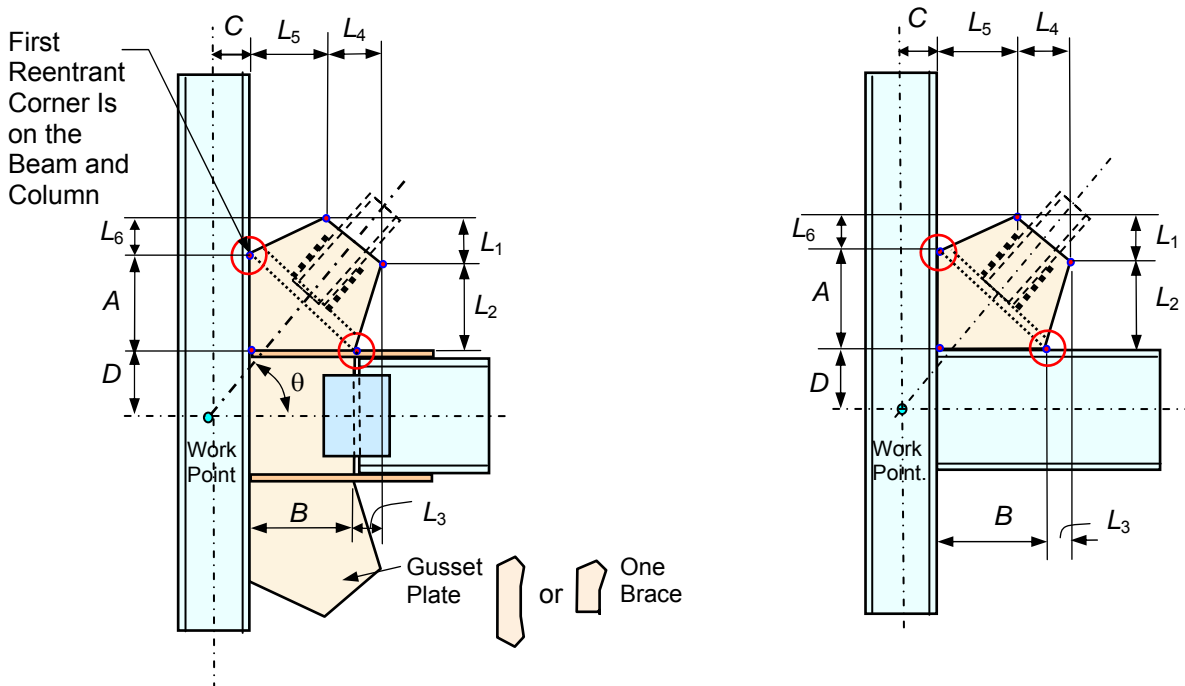
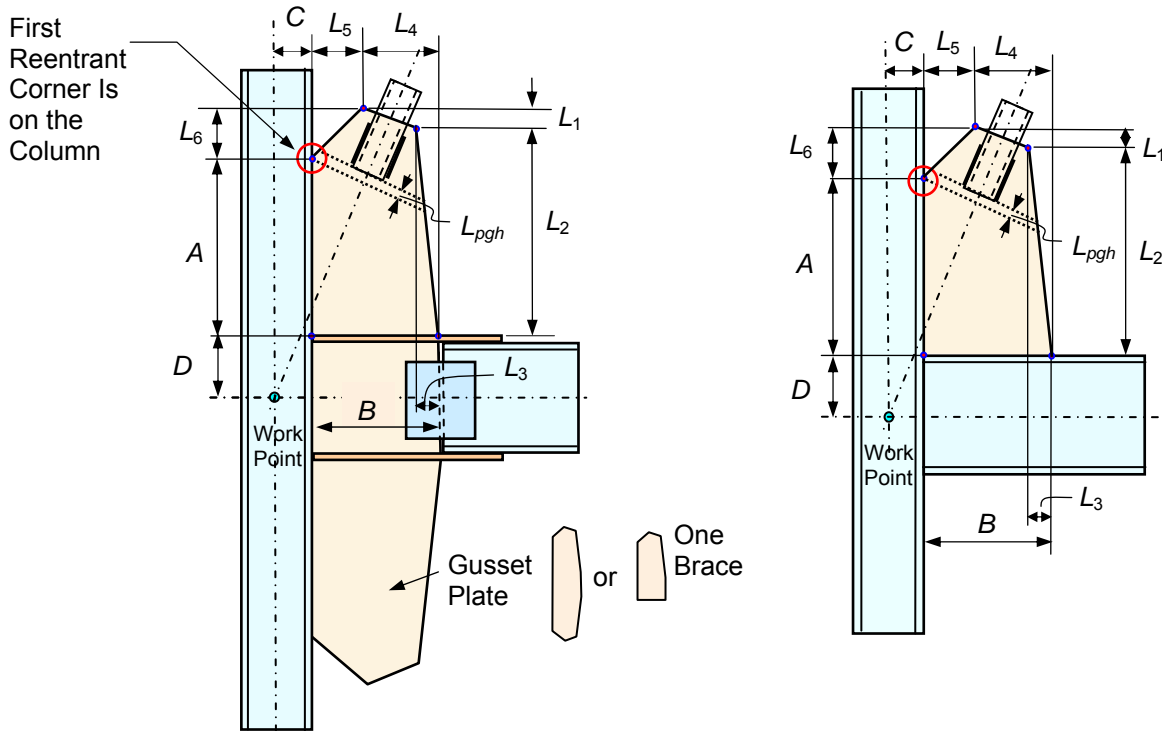

Graphics: Copyright © 2006 Abolhassan Astaneh-Asl. All rights reserved.

Figure 2.2. Dimensions A , B , and L_1 to L_6 for Gusset Plates (continued on next page)

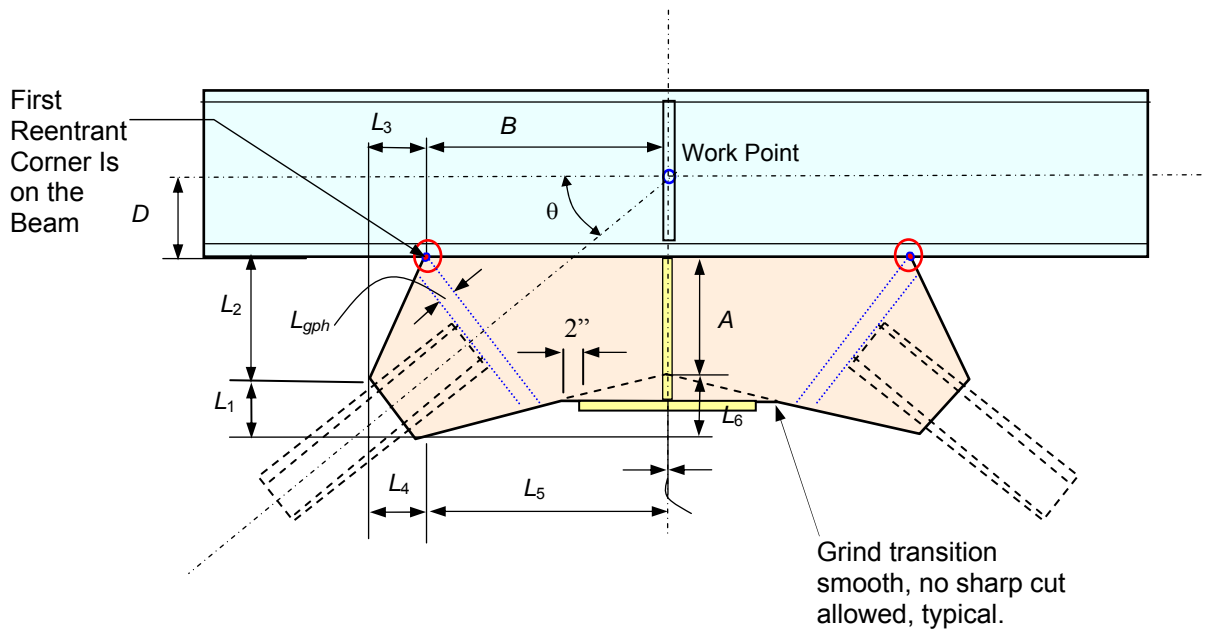

(d) Point of Intersection of the Line of Restraint Is on the Beam

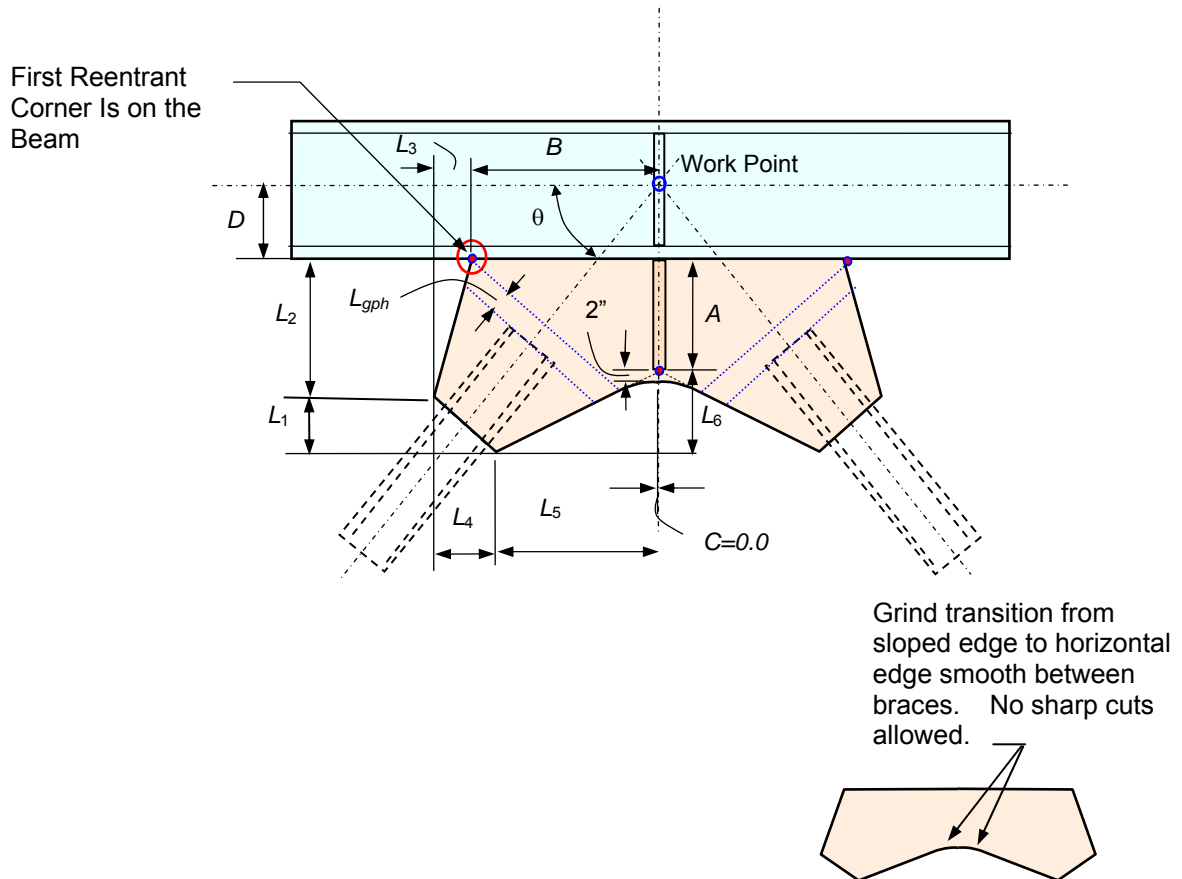

(e) Point of Intersection of the Line of Restraint Is on the Beam

Figure 2.2. Dimensions A , B , and L_1 to L_6 for Gusset Plates (*continued on next page*)

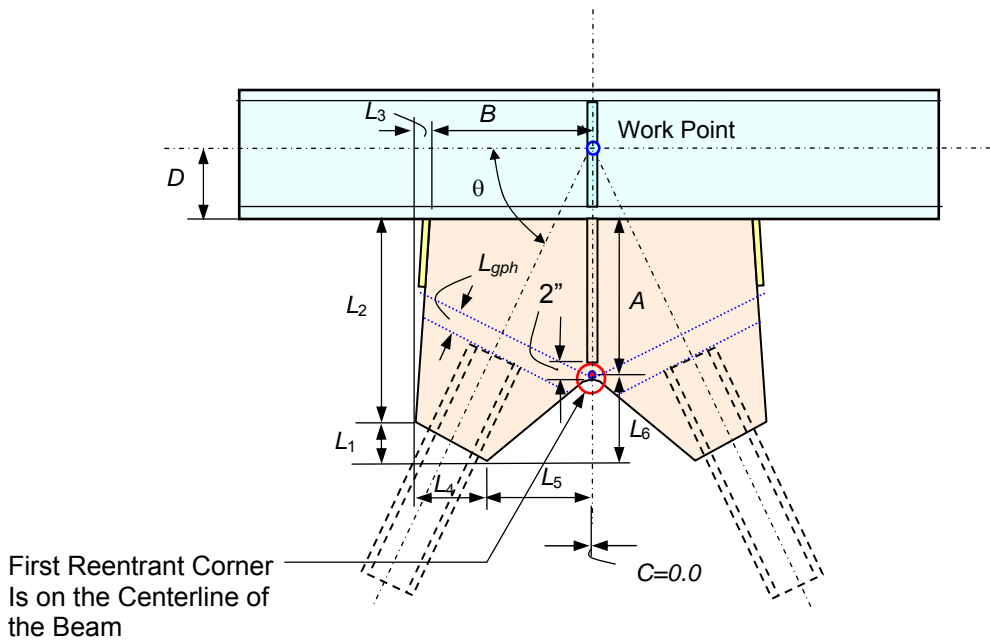

(f) Point of Intersection of the Line of Restraint Is on the Vertical Centerline

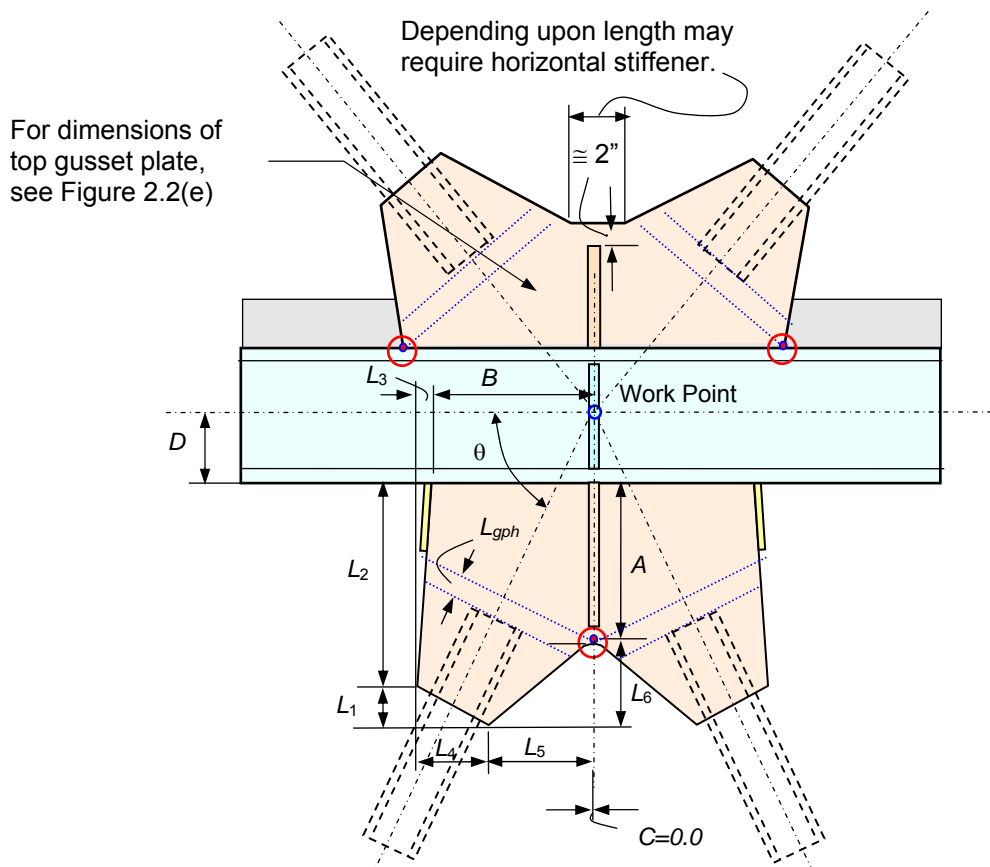

(g) Point of Intersection of the Line of Restraint Is on the Vertical Centerline

Figure 2.2. Dimensions A , B , and L_1 to L_6 for Gusset Plates (*continued*)

2.2. Selection of $2t$ Length

In this report the length of the gusset-plate hinge zone is denoted as L_{gph} . This length is typically a minimum of $2t$ (that is, twice the thickness of the gusset plate). Note that the length L_{gph} is the gusset-plate hinge-zone dimension along the axis of the bracing member measured from the end of the bracing member to the closest line of restraint that occurs at the reentrant corner of the gusset plate, Figure 2.1(b). To allow for some brace fit-up tolerance during field erection of the brace on the gusset plate, the designer should consider a hinge-zone length for the gusset larger than $2t$ such as $L_{gph} = 2t + \frac{3}{4}$ inch $\pm \frac{3}{4}$ inch for detailing and $L_{gph} = 2t + 1\frac{1}{2}$ inch for design purposes. As long as the hinge-zone buckling length L_{gph} of the installed brace/gusset-plate connection at each end of the brace does not become excessive at either gusset plate, the gusset will remain stable while providing adequate cyclic rotational ductility to accommodate the brace cyclic buckling expected in special concentrically braced frames. A maximum hinge-zone length dimension of $4t$ was recommended by Astaneh-Asl, Goel, and Hanson (1982) based on the range of their testing.

The following example demonstrates the reason for brace erection tolerances. During either shop fabrication or field erection of the braced frame bay, the brace may not be installed correctly centered between the connection gusset plates at each end as normally shown on the structural drawings. Instead the brace may be installed with a gusset-plate hinge-zone length of $2t + \frac{1}{4}$ inch on one end and $2t + 1\frac{1}{4}$ inch on the other end instead of an equal length of $2t + \frac{3}{4}$ inch at each end. Gusset-plate design should address accidentally created hinge-zone lengths longer than intended in the design due to the brace not being installed centered on the gusset plate at each end. The authors suggest that the length of the gusset-plate hinge zone L_{gph} shown on structural details not exceed $3t$ or $2t + \frac{3}{4}$ inch, whichever is smaller, in case the brace is installed off center between the end gusset plates, so that the actual hinge-zone length at either end of the brace will remain less than $4t$.

The length, L_b , for the brace lap onto the gusset plate when welding is used should be detailed 1 to 2 inches longer than the specified weld length, L_w , as shown in Figure 2.3. This allows for beginning and termination of the weld slightly away from the end of the brace member and end of the gusset plate. It also allows for additional welding should there be a field installation problem.

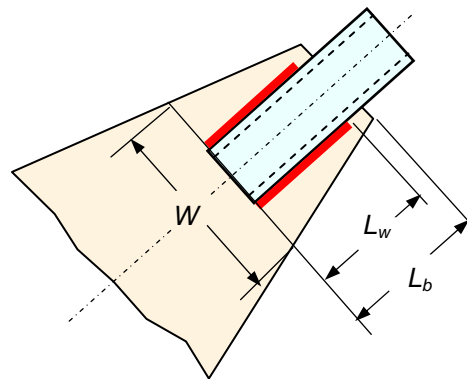

Figure 2.3. Length of Weld, L_w , and Length of Brace Lap on Gusset, L_b

When edge plates are provided to stiffen the free edge of the gusset plate, they should terminate outside the gusset-plate hinge zone as shown in Figure 2.4. This offset prevents the welds of the edge stiffener plate to the gusset plate from occurring in the area of gusset-plate rotation in the plastic hinge zone. Avoid wrapping the fillet weld around the edge of the gusset plate since it can cause an undercut in the gusset plate edge and possibly lead to fracture initiation in or near the gusset plate hinge-zone area where inelastic rotation will occur when the brace member buckles out of plane.

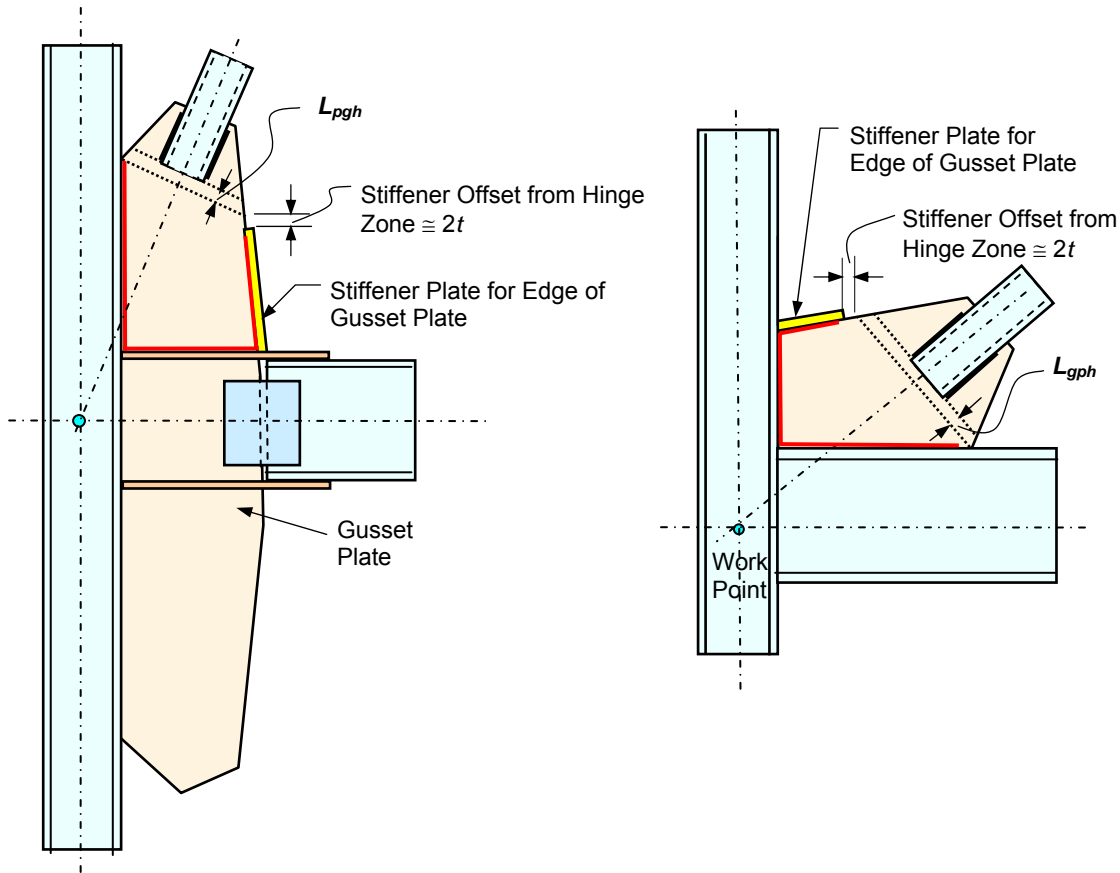

Figure 2.4. Edge Stiffeners and Offset Distance for Welds Near Plastic Hinge Zone

2.3. Computing Gusset Width at Hinge Zone, W , and Thickness of Gusset Plate, t

The width of the gusset plate at the hinge zone, W , shown in Figure 2.4, is one of the most important parameters in the design of gusset plates for out-of-plane buckling of bracing members. The required width, W , depends on the gusset thickness, the yield stress of the gusset plate, and, of course, the applied tension force. To establish the width of the gusset plate to resist the applied axial force, Whitmore's method is used. In this method, proposed by Whitmore (1952) for bolted gusset plates, as shown in Figure 2.5(a), 30-degree lines are drawn from the first bolt on the gusset to intersect the centerline axis of the last bolt. The width of the gusset

plate between the two intersection points is used in design as the effective width of the gusset plate to carry the applied load. The area outside this “Whitmore’s width” is not considered in design to resist applied load. Astaneh, Goel, and Hanson (1982) extended the use of Whitmore’s method to welded connections as shown in Figure 2.5(a) and suggested that, for welded connections, the 30-degree lines be drawn from the starting point of the weld to intersect a line passing through the end points of the weld. For more information on Whitmore’s width, the reader is referred to Whitmore (1952) or, for a brief summary, to Astaneh-Asl (1998).

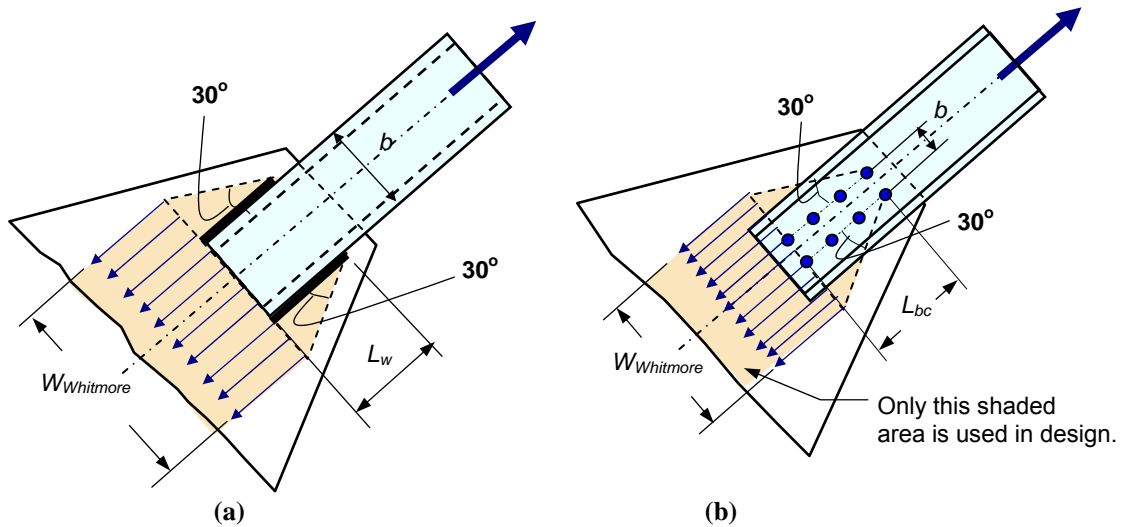

Figure 2.5. Whitmore’s Width, (a) for a Welded and (b) for a Bolted Gusset Plate

Whitmore’s width, $W_{Whitmore}$, can be calculated by using the following Equations 2.1a and 2.1b for welded and bolted connections, respectively (see Figure 2.5):

$$W_{Whitmore} = b + 2\sqrt{3} L_w \quad (\text{for welded member}) \quad (2.1a)$$

$$W_{Whitmore} = b + 2\sqrt{3} L_{bc} \quad (\text{for bolted member}) \quad (2.1b)$$

Where

$W_{Whitmore}$ = Width of the gusset plate at the end of the brace welding established using Whitmore’s method (shown in Figure 2.5)

L_w = Length of the weld connecting the bracing member to the gusset plate (Figure 2.5a)

L_{bc} = Length of the bolted connection of the bracing member to the gusset plate (Figure 2.5b)

b = Distance between the weld lines or bolt lines (Figure 2.5)

The width of the plate, W , at the cross section along the end of the weld lines (or bolt lines for bolted connections) is suggested to be equal or slightly less than the Whitmore’s width of $W_{Whitmore}$ such that the angle between the edge of the gusset plate and the axis of the brace member, shown as α_1 and α_2 in Figure 2.6, are between 25 and 30 degrees. Where the actual value of W exceeds $W_{Whitmore}$, the material outside of the Whitmore width cannot be utilized in the design and is therefore wasted. Furthermore, the additional width moves the gusset-plate line of

restraint further from the connection work point, making the gusset plate larger in the direction of the brace axis as well, and thus increasing the gusset-plate buckling length.

After selection of W , the thickness of the gusset plate can be calculated as:

$$t = T_r / (\phi_y F_{ypl} W) \quad (2.2)$$

Where

- t = Thickness of the gusset plate
- T_r = Maximum required tensile strength for connection design. T_r for special concentrically braced frames is given in Section 13 of the AISC Seismic Provisions (AISC 2005c) as the lesser of the following:
 - a. The expected yield strength, in tension, of the bracing member, determined as $R_y F_y A_g$ (LRFD) and $R_y F_y A_g / 1.5$ (ASD), as appropriate
 - b. The maximum *load effect*, indicated by analysis that can be transferred to the brace by the system
- R_y = Ratio of the expected yield stress to the specified minimum yield stress, F_y . R_y values for various steel are given in Table I-6-1 of the AISC Seismic Provisions (AISC 2005c).
- F_y = Specified minimum yield stress of the bracing member material
- $R_y F_y$ = Expected yield stress of the bracing member
- A_g = Gross area of the bracing member
- ϕ_y = Resistance factor for yielding of the gross area in LRFD = 0.90
- F_{ypl} = Specified minimum yield stress of the gusset-plate material
- W = Width of the gusset plate at the end of the brace (measured perpendicular to the brace axis); see Figures 2.3 and 2.5.

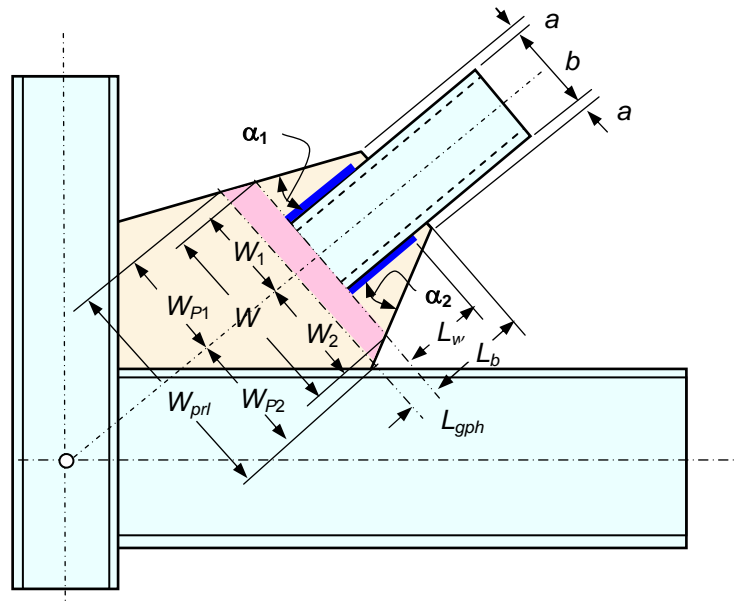

Figure 2.6. Widths of Gusset Plate Corresponding to Angles α_1 and α_2

2.4. Calculating Angles α_1 and α_2

The authors recommend using gusset plates symmetric about their brace axis. This will permit efficient use of the gusset-plate material at its most highly stressed section at the end of the brace. Keeping the gusset centered on the brace axis results in dimensions W_1 and W_2 as well as angles α_1 and α_2 in Figure 2.6 being equal.

From geometry of the gusset plate in Figure 2.6, angles α_1 and α_2 can be calculated from:

$$\alpha_1 = \tan^{-1} [(W_1 - b/2 - a) / L_b] \quad (2.3)$$

$$\alpha_2 = \tan^{-1} [(W_2 - b/2 - a) / L_b] \quad (2.4)$$

Where

α_1 and α_2 = Angle of the gusset edge to the brace axis (shown in Figure 2.6)

W_1 = Portion of the width of the gusset plate at the end of the brace (measured perpendicular to the brace axis) corresponding to angle α_1 (shown in Figure 2.6)

W_2 = Portion of the width of the gusset plate at the end of the brace (measured perpendicular to the brace axis) corresponding to angle α_2 (shown in Figure 2.6)

a = Distance from the face of the bracing to the edge of the gusset plate (shown in Figure 2.6)

b = Width of the bracing member on the gusset plate (shown in Figure 2.6)

L_b = Length of brace member lap on the gusset plate (shown in Figure 2.6)

If angles α_1 and α_2 are not equal, they should preferably not differ from each other by more than 2 degrees. As mentioned earlier, for efficiency of design, angles α_1 and α_2 are preferred to be between 25 and 30 degrees.

Dimensions W_{P1} and W_{P2} are shown in Figure 2.6 and are given by the following equations:

$$W_{P1} = a + b / 2 + (L_b + L_{gph}) \tan(\alpha_1) = W_1 + L_{gph} \tan(\alpha_1) \quad (2.5)$$

$$W_{P2} = a + b / 2 + (L_b + L_{gph}) \tan(\alpha_2) = W_2 + L_{gph} \tan(\alpha_2) \quad (2.6)$$

$$W_{prl} = W_{P1} + W_{P2} \quad (2.7)$$

$$W_{prl} = (2a + b) + (L_b + L_{gph}) \tan(\alpha_1) + (L_b + L_{gph}) \tan(\alpha_2) \quad (2.8)$$

2.5. Establishing Gusset Dimensions A , B , and L_1 to L_6

The parameters that are needed to establish dimensions A , B , and L_1 to L_6 of the gusset plate are a , b , C , D , t , L_b , and L_{gph} and angles θ , α_1 , and α_2 . For definition of these parameters see the “Notations” section on page 4. Depending on the angle θ , the depth of the column, C , and the depth of the beam, D , the gusset-plate first line of restraint will be on the beam flange, Figure

2.7, or on the column flange, Figure 2.8. In a special case the first line of restraint will intersect both the beam and the column flange, Figure 2.9. The following section provides information on how to establish the location of the first line of restraint point of intersection.

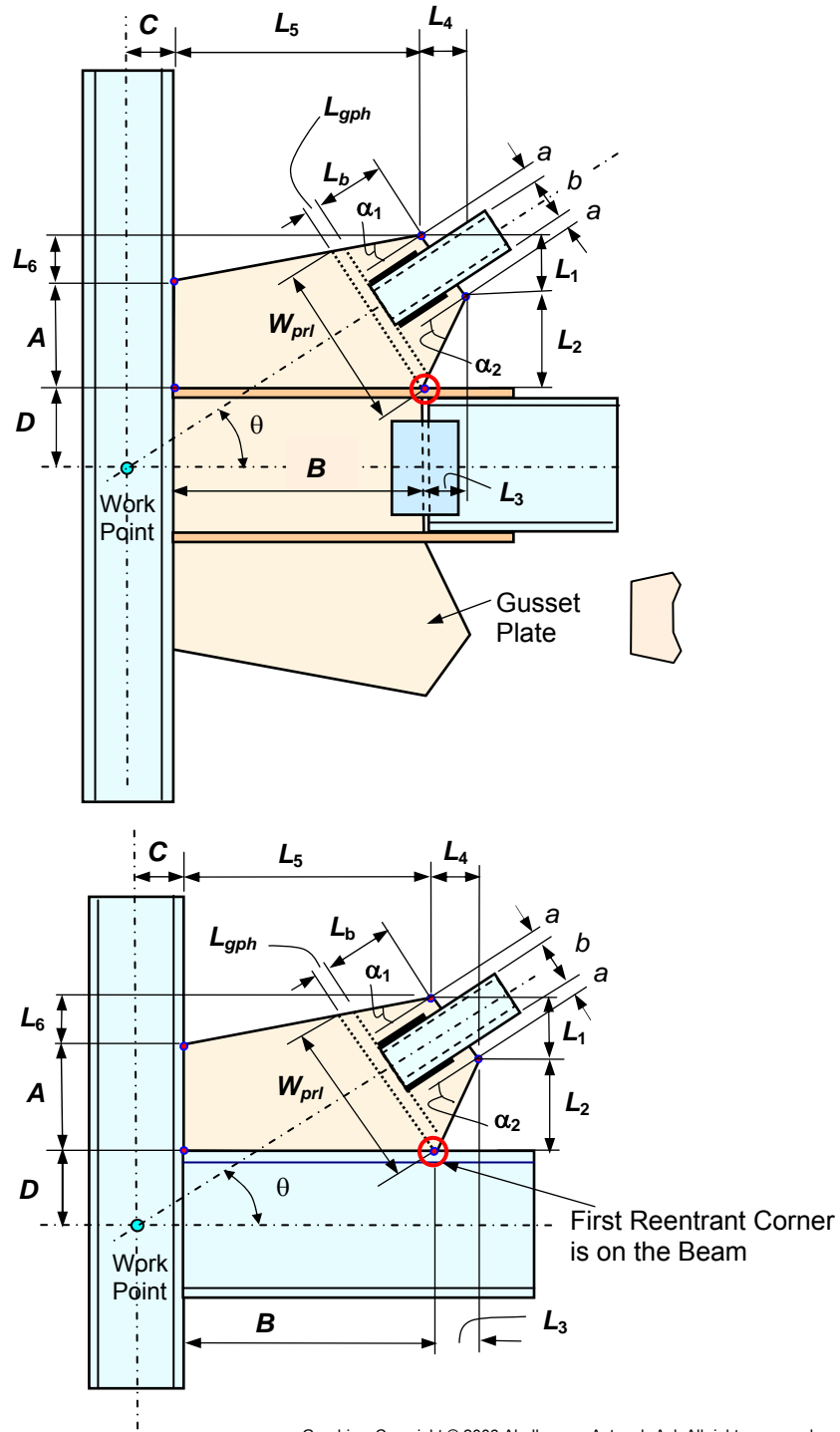

Graphics: Copyright © 2006 Abolhassan Astaneh-Asl. All rights reserved.

Figure 2.7. Intersection of the Plastic-Hinge-Zone Restraint Line with the Beam

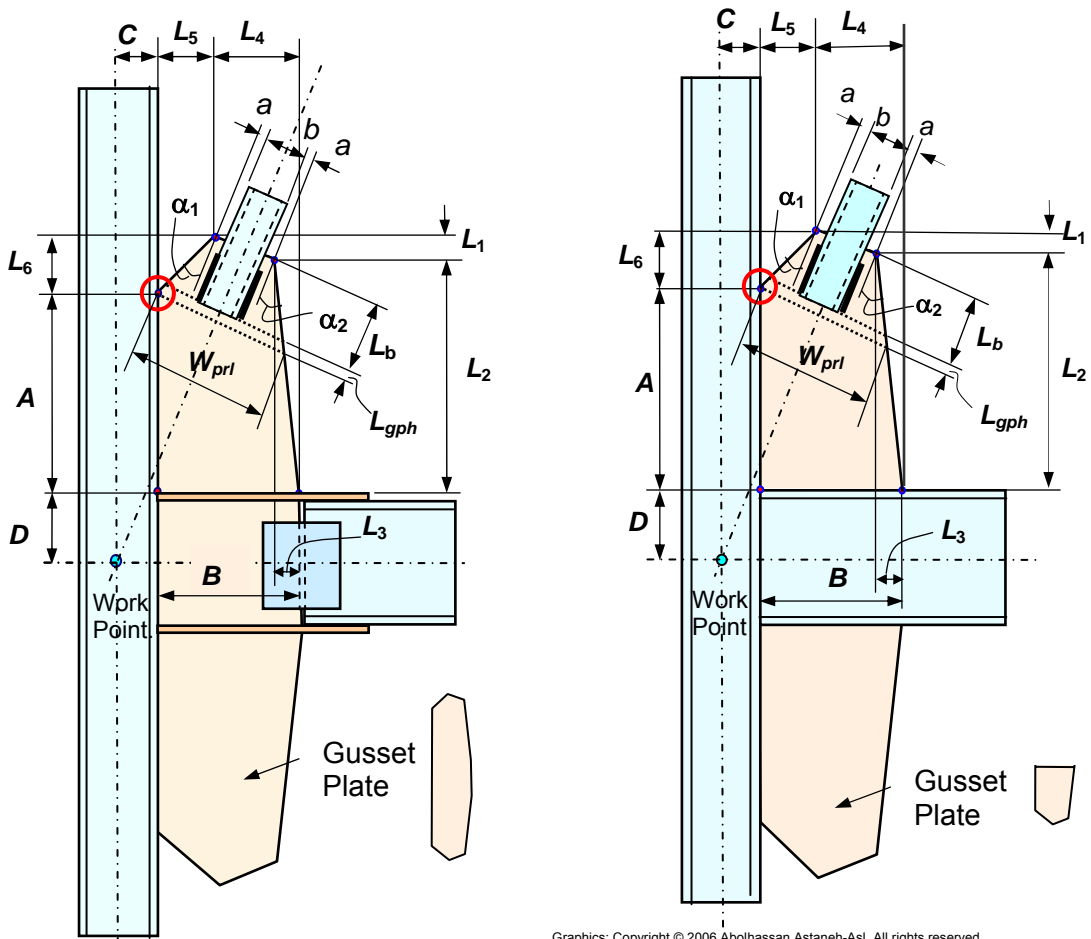

Graphics: Copyright © 2006 Abolhassan Astaneh-Asl. All rights reserved.

Figure 2.8. Intersection of the Plastic-Hinge-Zone Restraint Line with the Column

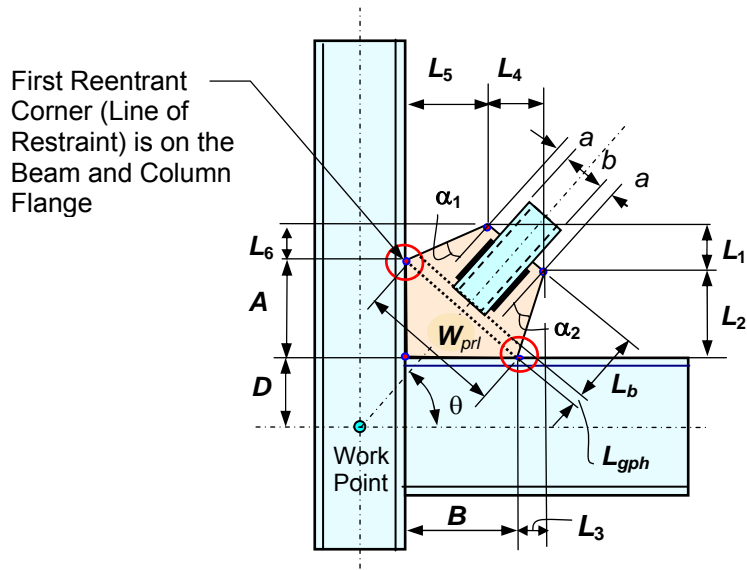

Graphics: Copyright © 2006 Abolhassan Astaneh-Asl. All rights reserved.

Figure 2.9. Intersection of the Plastic-Hinge-Zone Restraint Line with Both the Beam and the Column (Special Case)

2.5.a. Determining whether the first re-entrant corner is at the beam or the column flange

Determining whether the first reentrant corner of the gusset plate (line of restraint) will occur at the column or the beam flange (or both simultaneously) is dependent on many variables: brace slope, beam and column depths, gusset angles α_1 and α_2 , and the gusset width. Minor changes to any of these can change the location of the gusset-plate first line of restraint and the size of the gusset plate.

In order to establish whether the first line of restraint occurs at the reentrant gusset corner at the column or the one at the beam, consider the gusset plates in Figure 2.10 where the first line of restraint point of intersection is shown on the column to define the geometry of the connection. A parameter U is defined as:

$$U = C_1 - C_2 \quad (2.9)$$

Where C_1 and C_2 are vertical coordinates at the centerline of the column of two intersection lines 1 and 2 as shown in Figure 2.10. Line 1 is a line perpendicular to the axis of the brace and passes through the reentrant corner of the gusset plate on the column. Line 2 is also perpendicular to the axis of the brace, but this line passes through point a on the beam as shown in Figure 2.10. Point a is found by drawing a line parallel to the axis of the brace starting from the edge of the gusset plate at W_{P2} and intersecting this line with the beam flange.

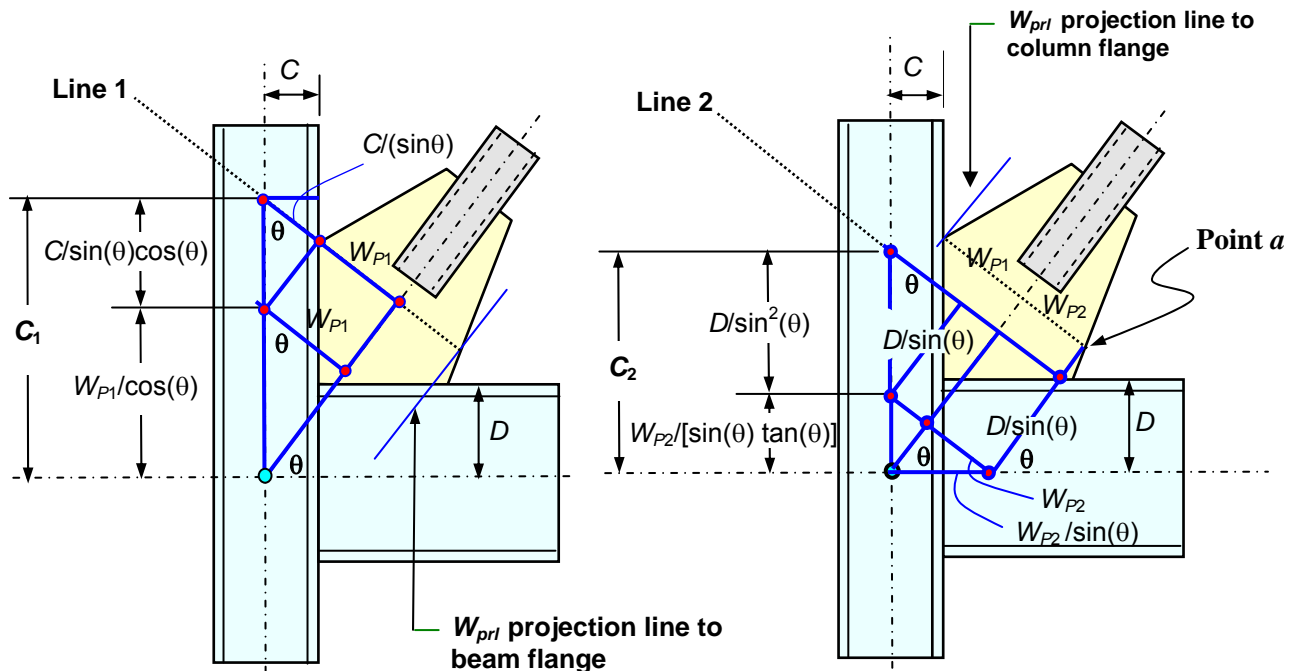

Figure 2.10. Dimensions Used to Derive Equation 2.9 for U Function

The values of C_1 and C_2 are calculated from the geometry of the gusset plates shown in Figure 2.10 as:

$$C_1 = \frac{C}{\sin(\theta)\cos(\theta)} + \frac{W_{P1}}{\cos(\theta)} \quad (2.10)$$

$$C_2 = \frac{D}{\sin^2(\theta)} + \frac{W_{P2}}{\sin(\theta)\tan(\theta)} \quad (2.11)$$

Where,

C = For cases where the gusset plate is connected to the flange of the column, the horizontal distance from the work point to the column flange connected to the gusset plate as shown in Figures 2.7, 2.8, and 2.9. For double symmetric columns, C would be half the column depth. For cases where the gusset plate is connected to the web of the column (see Figure 3.4 in Chapter 3), parameter C is the horizontal distance from the work point to the tip of the gusset-plate stiffener.

D = Vertical distance from the work point to the beam flange connected to the gusset plate as shown in Figures 2.7, 2.8, and 2.9. For double symmetric horizontal beams, D would be half the beam depth.

Both C_1 and C_2 are vertical dimensions measured from the intersection of the beam and column centerlines to the intersection of the line of restraint and the column centerline. C_1 is based upon the perpendicular line passing through the column flange reentrant corner (or the W_{prl} projection line at the column flange), and C_2 is based upon the perpendicular line passing through the beam flange reentrant corner (or the W_{prl} projection line at the beam flange). Steep brace angles and deeper columns will result in a large C_1 ; shallow brace angles and deeper beams will result in a large C_2 . Thus which line of restraint governs depends on the brace angle and relative column and beam depth; shallow brace angles, deeper beams, and shallower columns will tend to make the first reentrant corner occur on the beam flange, and the opposite will tend to make the first reentrant corner occur on the column flange.

By comparing values of C_1 and C_2 , the location of the line of first restraint point of intersection, whether being on the beam flange, on the column flange, or both, can be established as follows:

- (1) If $U > 0$ then the point of intersection of the restraint line is on the column
- (2) If $U < 0$ then the point of intersection of the restraint line is on the beam; and
- (3) If $U = 0$ then the point of intersection of the restraint line is on the beam as well as on the column.

In the following sections, equations for the three cases of the gusset-plate reentrant corner intersecting the beam, the column, or both are provided. The parameter U , and also the eight gusset-plate dimensions given in the following sections, have been defined and established for gusset-plate connections with horizontal beams. For connections with sloped beams, the reader is referred to Appendix B of this Steel TIPS report. For gusset plates at the base of columns, see Appendix C.

The equations that follow can be programmed into a spreadsheet to calculate the dimensions of the gusset plate automatically. One such spreadsheet has been developed by the first author, A. Astaneh-Asl, and is offered by Engineering & Publishing Services (EPS). For more information on this spreadsheet and how to obtain a copy, the interested reader is referred to the EPS web site, <http://www.ENG PUB.com>. The spreadsheet calculates gusset dimensions for connections with horizontal and sloped beams as well as connections at the base of columns.

2.5.b. Establishing gusset dimensions A , B , and L_1 to L_6 when the point of intersection of the restraint line (the first reentrant corner) is on the beam

Referring to Figure 2.7, the following relationships can be established among various dimensions of gusset-plate geometry when the intersection of the restraint line is on the beam.

$$L_1 = (2a + b) \cos(\theta) \quad (2.12)$$

$$L_2 = \left(\frac{L_{gph} + L_b}{\cos(\alpha_2)} \right) \sin(\theta + \alpha_2) \quad (2.13)$$

$$L_3 = \frac{L_2}{\tan(\theta + \alpha_2)} \quad (2.14)$$

$$B = \frac{D}{\tan(\theta)} + \frac{W_{P2}}{\sin(\theta)} - C \quad (2.15)$$

$$L_4 = (2a + b) \sin(\theta) \quad (2.16)$$

$$L_5 = B + L_3 - L_4 \quad (2.17)$$

$$L_6 = L_5 \tan(\theta - \alpha_1) \quad (2.18)$$

$$A = L_1 + L_2 - L_6 \quad (2.19)$$

For definition of the terms in the preceding equations, please see the “Notations” section on page 4 and Figures 2.7, 2.8, and 2.9.

2.5.c. Establishing gusset dimensions A , B , and L_1 to L_6 when the point of intersection of the restraint line (the first reentrant corner) is on the column

Referring to Figure 2.8, the following relationships can be established among the various

dimensions of gusset-plate geometry.

$$L_6 = [(L_{gph} + L_b) / \cos(\alpha_1)] \sin(\theta - \alpha_1) \quad (2.20)$$

$$L_5 = [(L_{gph} + L_b) / \cos(\alpha_1)] \cos(\theta - \alpha_1) \quad (2.21)$$

$$L_4 = (2a + b) \sin(\theta) \quad (2.22)$$

$$A = C \tan(\theta) + \frac{W_{p1}}{\cos(\theta)} - D \quad (2.23)$$

$$L_1 = (2a + b) \cos(\theta) \quad (2.24)$$

$$L_2 = A + L_6 - L_1 \quad (2.25)$$

$$L_3 = L_2 \tan(90^\circ - \theta - \alpha_2) \quad (2.26)$$

$$B = L_4 + L_5 - L_3 \quad (2.27)$$

2.5.d. Establishing gusset dimensions A , B , and L_1 to L_6 when the point of intersection of the restraint line (the first reentrant corner) is on the column as well as on the beam

Referring to Figure 2.9, for this special case, the intersection of the restraint line is both on the beam as well as on the column. For this special case, either set of the preceding equations given for intersection on the beam or on the column can be used.

Figure 2.11 shows examples of gusset-plate geometries resulting from using the preceding equations.

2.6. Gusset-Plate Detailing

Once the gusset-plate design is complete, the information needs to be shown on the structural drawings. The gusset-plate design is based upon specific dimensions (bay width, floor to floor height, beam and column depths), and any changes in these dimensions will change the gusset-plate dimensions, particularly those that depend on the location of the hinge zone. There may be minor changes in the brace frame bay width dimensions or beam sizes after completion of the braced frame design requiring the gusset dimension to be modified, so some dimensional tolerances need to be allowed for in gusset-plate dimensioning. Another area where gusset design may require adjustment is at roof connections. Where the gusset design has been based upon a level beam, a sloped roof beam will require a somewhat different gusset.

The information shown on the structural plans should allow the steel detailer or fabricator some tolerance on the design of the gusset plate to address minor changes. If the engineers show all of the required gusset-plate dimensions, some of the dimensions are likely to require adjustment when the detailer checks the design, so the detailer may submit the shop drawings to

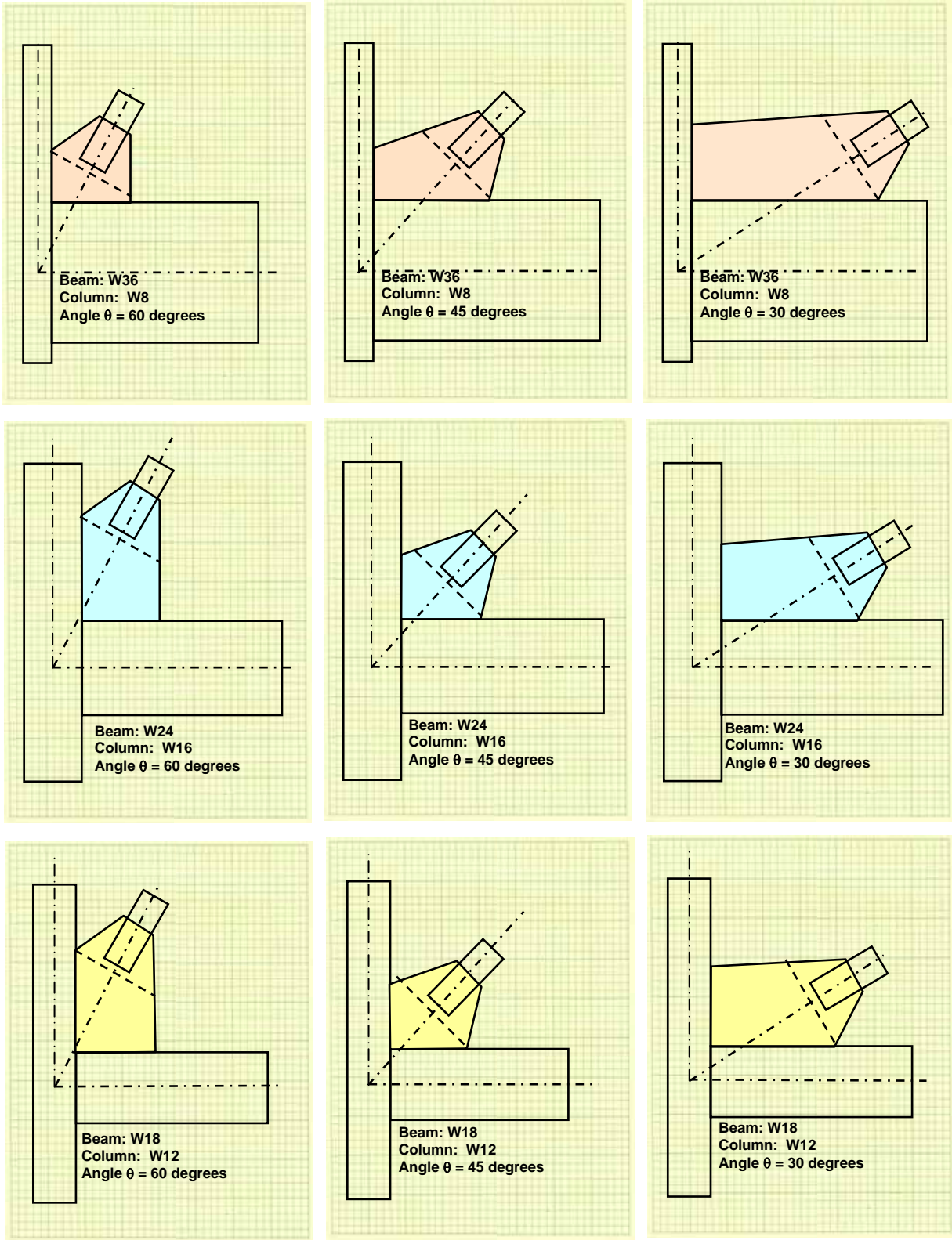

Figure 2.11. Examples of Gusset Plates Resulting from Equations in the Text

the designer asking which requirements take precedence. Therefore, it may be best to not show all of the required gusset-plate dimensions but to allow the detailer to finalize the dimensions and slopes. The dimensions that are recommended to be shown are one of the angles α_1 or α_2 , a , L_w , L_b , and L_{gph} . The designer can give one of the dimensions A or B if she or he wishes. Some engineers prefer not to give the dimensions A or B . These dimensions are then determined by the detailer based on the brace slope, the angles α_1 and α , a , L_w , L_{gph} , L_b , and the beam and column depths using the equations provided earlier.

Figure 2.12 shows suggested gusset detail information (dimensions and tolerances) and a “Fabricator Notes for Gusset Plate Dimensioning” section for gusset plates to possibly be shown on the structural drawings.

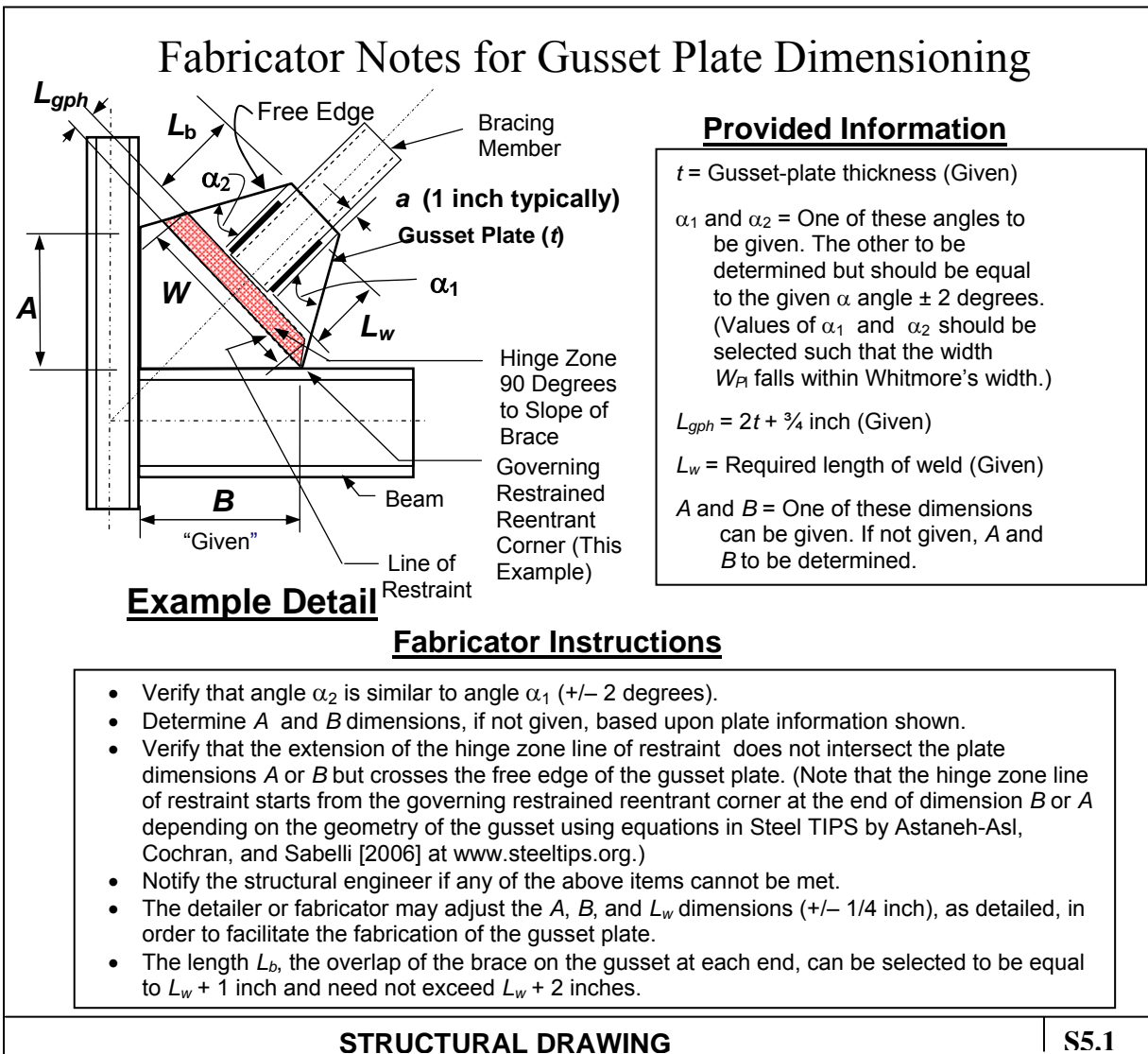
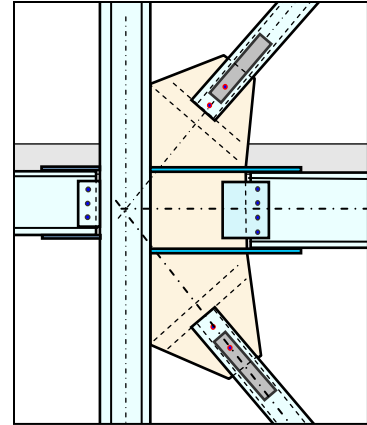

Figure 2.12. Example of a Fabricator Detailing Note to Be Placed on Drawings (Brace to Column Connection)

The hinge-zone width, L_{pgh} , is specified to be a range as discussed earlier and provided on the drawings for detailing purposes. The slope of the side of the gusset (α_1 and α_2) is selected as described in Section 2.4 earlier. L_w is the required weld length, and L_b is the length of overlap of the brace onto the gusset. Length B or A can also be provided. Note that in deciding which dimension, A or B , should be given, usually the dimension on the side where the gusset-plate hinge zone is first restrained (see Fig 2.12) is given. The given slope (α_1 or α_2) is usually associated on the side of the brace for which dimension A or B is provided. The fabricator can then determine length A and verify that the slope of the gusset edge angle that is not given is within the tolerance of the given edge angle, preferably the same as the given angle or differing from it by not more than 2 degrees. Notes like those listed as “Fabricator Instructions” in Figure 2.12 giving direction to the fabricator on required tolerances and what to check may be provided on the structural drawings. A summary table can be established on the structural drawings for the various dimensions of the gusset plate. Other variations of detailing requirements and tolerances for various gusset-plate shapes are possible than those suggested here. For the suggested details shown in Chapter 3, the gusset-plate detailing requirements may be different from those shown in Figure 2.12.

One important item to require of the steel shop drawings is for the gusset plates to be drawn to scale for each location so the engineer can verify that they comply with the original design intent. In some cases, a problem is caused when the engineer uses a generic $\theta = 45$ degree drawing to fit all of the gusset information. When the fabricator lays the gussets out and sends shop drawings for approval, it is not unusual to find that the gussets are a great deal larger than expected. This can cause considerable problems, both due to conflicts with doorways, mechanical ducts, and so on, and due to larger-than expected buckling lengths for the gusset plate. If the gusset-plate vertical dimension has become too large and crosses over the column field splice, this can become a fabrication/erection issue. To avoid these problems, it is suggested that gusset plates be drawn to scale using the actual value of angle θ as well as the actual beam and column depths.

3. SUGGESTED GUSSET-PLATE DETAILS FOR SCBFs



3.1. Introduction

This chapter provides a number of suggested details for gusset-plate connections of special concentrically braced frames. As discussed in Chapter 2, when in single gusset-plate connections, the bracing member buckles out of plane of the gusset, a minimum distance of L_{gph} equal to $2t$ is required in the gusset plate to provide room for the formation of a plastic hinge in the gusset. The suggested details are not meant to be the only appropriate details nor the most economical. The economy of design and construction depends on many variables, many of them beyond the scope of this document and the qualifications of the authors. These suggested details are developed in consultation with structural engineers, fabricators, and erectors and are suggested only as samples of connection details that satisfy the intent of the current AISC Seismic Provisions (AISC 2005c) and can be economical with current fabrication and erection procedures practiced by the fabricators who were consulted. Four major steel fabrication companies, two from the West Coast, one from the Midwest, and one from the East Coast were contacted for this report and provided very valuable information to the authors on gusset detailing. We have used those comments in developing the suggested details for gusset plates for SCBFs presented in this chapter.

3.2. Suggested Details for Single Gusset Plates of In-Plane Buckling Braces

When a bracing member buckles in the plane of the braced frame, which is the same plane as the plane of the gusset plate, the gusset plate remains almost elastic, and plastic hinges form in the brace member itself due to the relatively large in-plane stiffness and the strength of the gusset plate. In this case, there is no need to provide the $2t$ distance in the gusset plate. Figures 3.1 and 3.2 illustrate two suggested details for gusset plates for braces configured to buckle in plane. Figure 3.1 is for a wide flange brace and Figure 3.2 is for a double-angle brace with short legs of angles back to back.

3.3. Suggested Details for Single Gusset Plates of Out-of-Plane Buckling Braces

When a typical bracing member buckles out of plane of the frame, plastic hinges form in the gusset plates. In this case, there is a need to consider providing the $2t$ hinge zone in the gusset plate. Figures 3.3 through 3.8 show suggested details for braces configured to buckle out of

plane. Details in Figures 3.3 through 3.8 show wide-flange, double-channel, double-angle, and rectangular or round HSS bracings.

Appendix A to this report shows additional gusset-plate details for out-of-plane buckling braces. The details given in Appendix A are modified versions of some of the gusset-plate details currently used in special concentrically braced frames. The modifications are made to make the details more economical while enhancing their cyclic performance so that the connection can provide more ductility than the current version. In the opinion of the authors, the suggested details given in this chapter are expected to exhibit better performance and be easier to fabricate and more economical than those in Appendix A. The suggested details in this chapter should be used whenever possible over the details provided in the appendix.

3.4. General Notes for Details Shown in Figures 3.1–3.6 and in Appendixes A and B

The following notes are applicable to gusset-plate details shown in Figures 3.1 through 3.8, Figures A.1 through A.5 in Appendix A, and Figures B.4 and B.5 in Appendix B.

1. Gusset material should have a minimum specified yield stress, F_y , of 50 ksi. Buckling of the free edges of gusset plates should be investigated and edge stiffeners provided if needed (see Steel TIPS by A. Astanteh-Asl [1998]). The possibility of block shear failure at the connection of the brace to the gusset, especially for bolted connections, should be investigated. See Figures 3.1 through 3.8, A.1 through A.5, B.4 and B.5. When a gusset plate serves as the beam-to-column connection and has a reentrant corner (as in Figures 3.3, 3.4, 3.5, 3.6, 3.7 and 3.8) the reentrant corner should be cut with a transition radius and not a sharp notch.
2. Bolts in Figures 3.1 through 3.6, A.1 through A.5, B.4 and B.5 are slip-critical bolts designed as bearing bolts following the AISC Seismic Provisions (AISC 2005c). Note that the AISC Seismic Provisions also place limitations on bolt holes.
3. Welds in Figures 3.1 through 3.4, A.1, A.3, A.4, A.5, B.4 and B.5 connecting the gusset plate to column flange should be designed to develop R_y times the shear yield strength as well as the tensile yield strength of the gusset plate.
4. In Figures 3.2, 3.3, 3.4, 3.6, 3.7, 3.8, B.4 and B.5, a reinforcing plate is typically required for bolted SCBF brace connections to prevent net-section rupture from becoming the governing failure mode, which would not be acceptable for SCBFs.
5. The L_{gph} is the length of the gusset-plate plastic hinge zone when the member buckles out of plane of the gusset plate as is the case for details in Figures 3.3, 3.4, 3.5, 3.6, 3.7, 3.8, A.1 through A.5, B.4 and B.5. The value of L_{gph} should satisfy: $2t \leq L_{gph} \leq 4t$. A length of $2t + 3/4$ inch is recommended as a practical value for L_{gph} . This length is needed only in gusset plates where the member buckles out of plane of the gusset, bending it and forming a plastic hinge in this L_{gph} region. If the brace buckles in the plane of the gusset, as is the case in details given in Figures 3.1 and 3.2, there is no need for a $2t$ hinge zone.

6. At least one erection aid (for example, a bolt hole) should be provided at each end of the bracing members; see Figures 3.2, 3.3, 3.6, 3.7, 3.8, A.4, B.4 and B.5. Erection aids should also be provided on the single plate at approximately 6 inches center-to-center spacing.
7. The width of the slotted lap plate in Figures 3.1 through 3.5, A.3, B.4 and B.5 for the top flange is preferred to be less than the beam flange width and for the bottom flange greater than the beam flange width to allow for down welding. However, beam top and bottom flange lap plates that are both the same width are also acceptable but may require overhead welding for one of the plates. The width of the top and bottom flange lap plates should not be the same as the width of the beam flange for welded connections. If there are detailing or fabrication errors that prevent the bolts from aligning, the connection cannot be field-welded without field cutting the lap plate width enough to provide clearance for field welding to the beam flanges. Reducing the lap plate width could also cause design inadequacies.
8. Lap plates and single plates on the beams in Figures 3.1 through 3.5, 3.8, B.4 and B.5 should be designed for combined axial and shear forces and bending moments established using a rational analysis method satisfying equilibrium and compatibility of deformations.
9. Where a single plate (on the column) is used, it should be designed for combined axial and shear forces and bending moments established using a rational gusset-plate analysis method satisfying equilibrium and compatibility of deformations. See Figures A.1 through A.4 in Appendix A.
10. If the thicknesses of the gusset and beam web in Figures A.1 through A.5 differ by more than $3/16$ inch, welded shim plates need to be provided either on the beam web or on the gusset plate to make the thicknesses of the web and gusset plate the same. If the difference in thicknesses is less than $3/16$, the gusset plate can be slightly eccentric with respect to the beam web to make the front surfaces of the gusset and the beam web in the same plane.
11. Where a single plate extending from the column web is used, as is the case in Figures 3.4, A.3, B.4 and B.5, it should be designed to resist the forces and moments that the beam imposes on its support. The procedure for the design of extended shear tabs given in a Steel TIPS Report by A. A. A. (2005) or another strength-design method that is based on a hierarchy of failure modes ensuring yielding to be the governing failure mode can be used for this purpose.
12. The need for gusset plate edge stiffeners can be checked by following the procedures given in the Steel TIPS by A. A. A. (1998).
13. Additional gusset plate bracing may be required to prevent out-of-plane buckling of the beam mid-span gusset plate, especially, when the gusset plate projects a long distance below the bottom of the beam as shown in Figure 3.6.

3.5. Suggested Details for Gusset Plates of Special Concentrically Braced Frames

Figures 3.1 through 3.8 show gusset-plate details suggested by the authors for special concentrically braced frames. The details are developed using components from design done by structural engineers or fabricators as indicated in the “Credit” note below the figures. The details are expected to perform in a sufficiently ductile manner under cyclic loading to qualify them to be part of special concentrically braced frames. In addition, in developing these details, the authors have benefited from the review comments and input by the engineers from four major steel fabrication and erection companies, two from the West Coast, one from the Midwest, and one from the East Coast. As a result, the authors believe these connections can result in ductile, yet economical steel structures that are easy to design, fabricate, and erect.

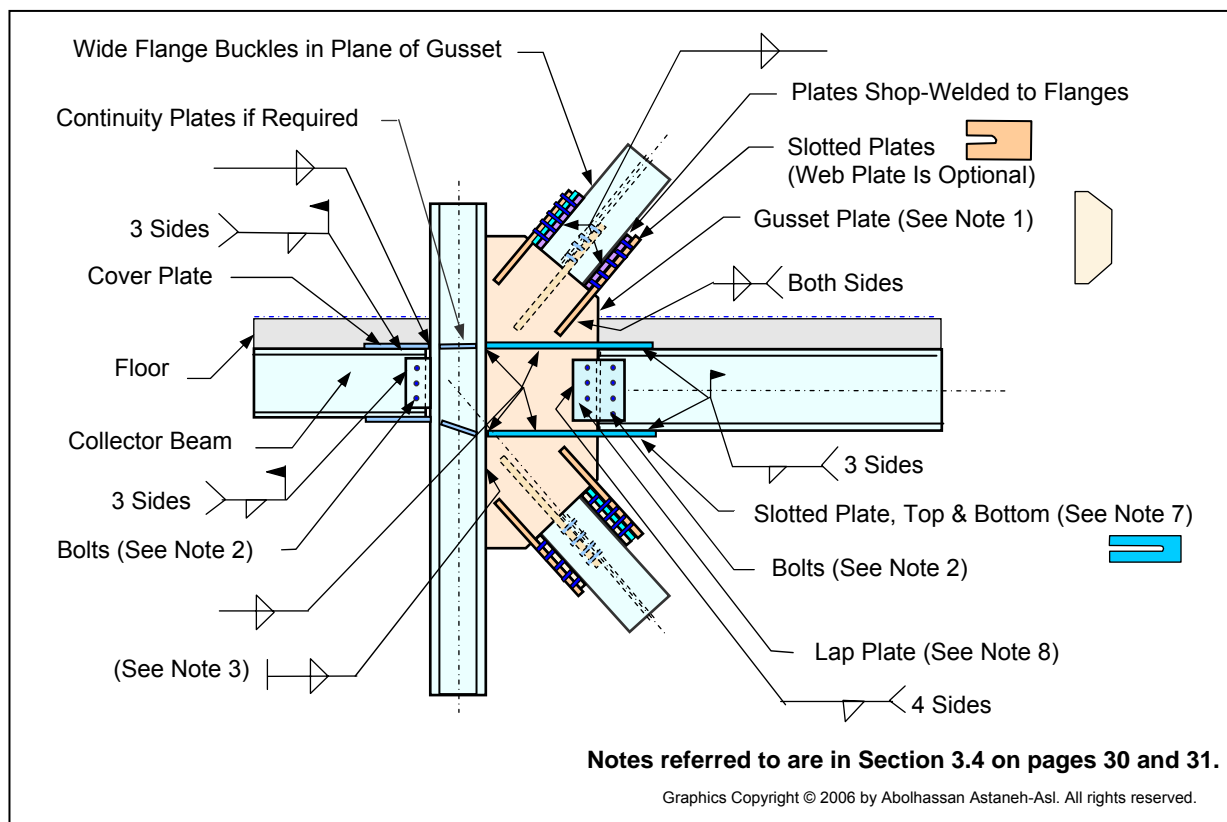

Figure 3.1. Suggested Detail for Gusset Plates of In-Plane Buckling Wide Flange Brace Members

(Credit: The above detail was developed by using designs by the Cives Steel Company for the connection of braces to the gusset and Brian L. Cochran Associates, Inc., Consulting Structural Engineers, Los Angeles, for the rest of the data.)

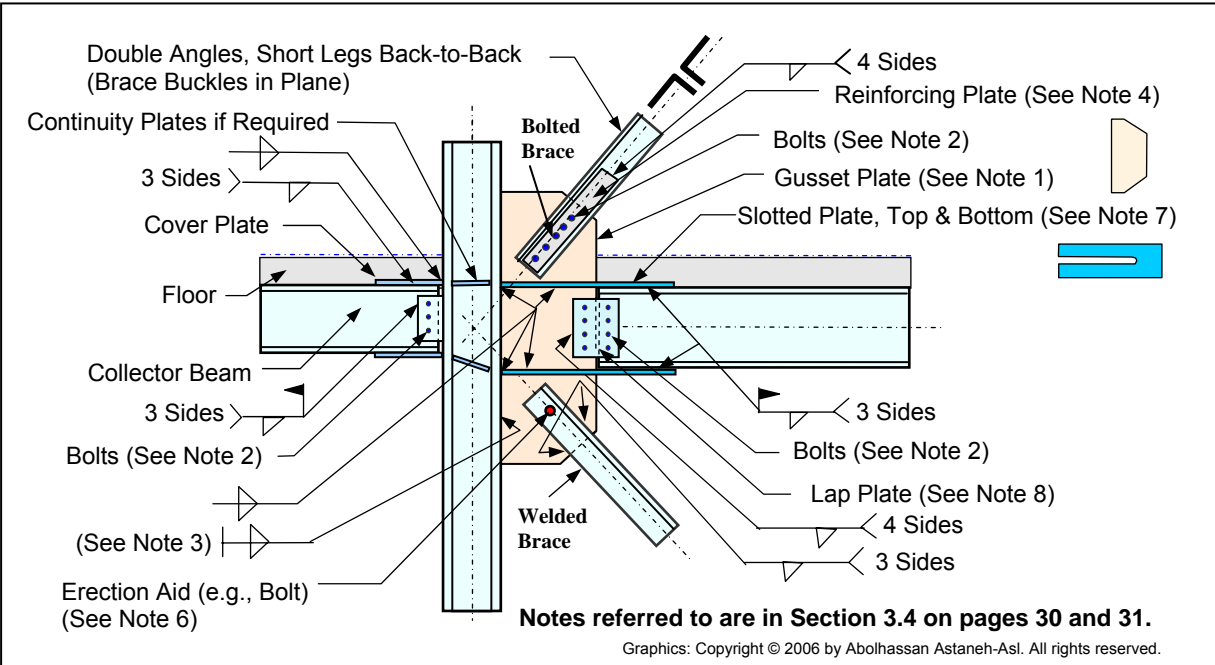

Figure 3.2. Suggested Detail for Gusset Plates of In-Plane Buckling Double Angles
 (Credit: The above gusset/brace connection for in-plane buckling double-angle braces is taken from Astanteh-Asl, Goel, and Hanson [1982]).

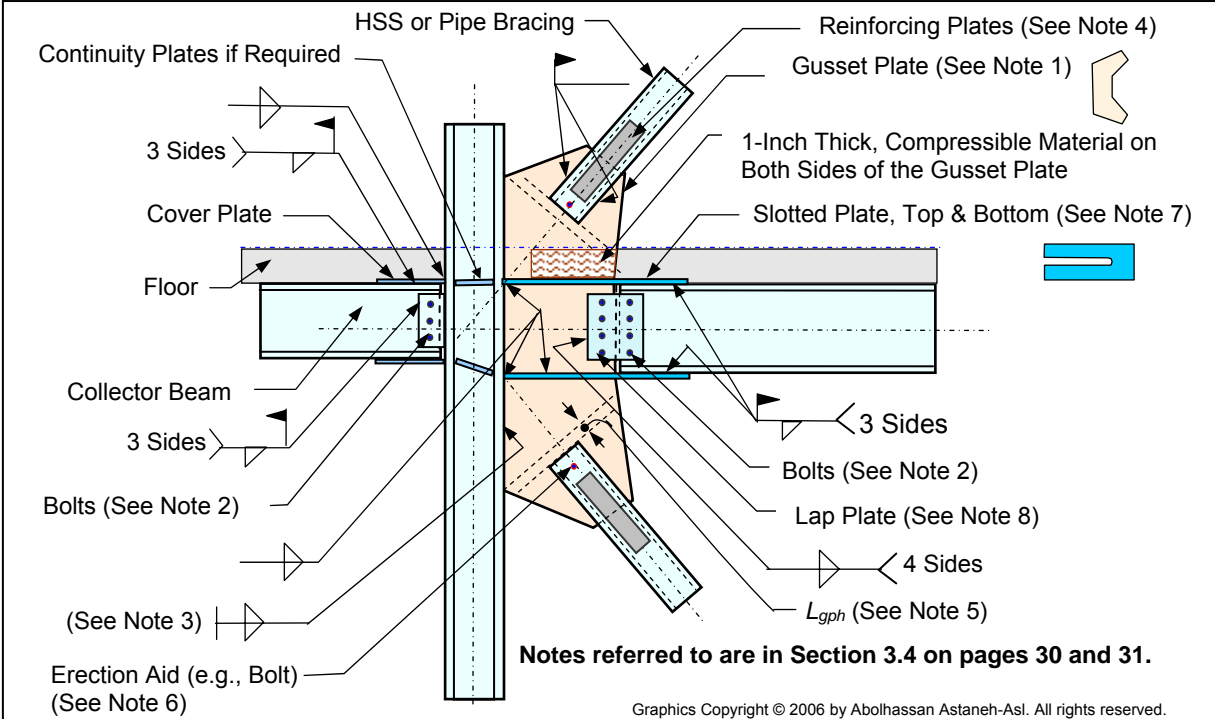

Figure 3.3. Suggested Detail for Gusset Plates of HSS Brace Members
 (Credit: The above connection was developed by Brian L. Cochran Associates, Inc., Consulting Structural Engineers, Los Angeles, and is presented herein with permission.)

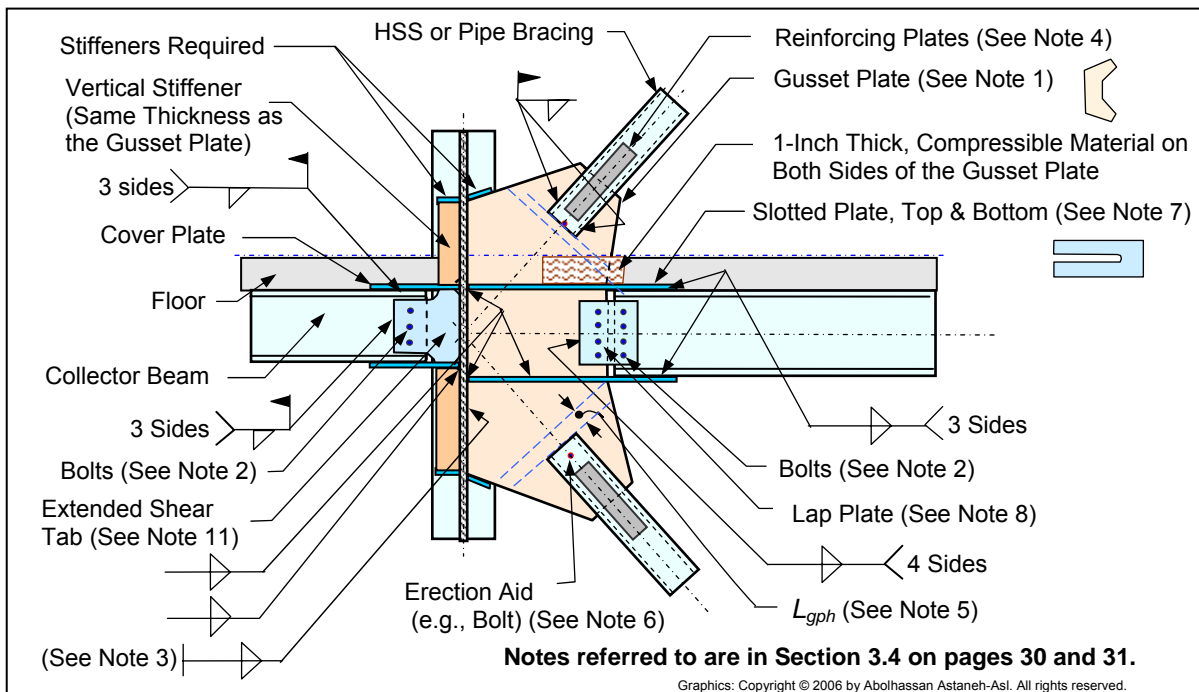

Figure 3.4. Suggested Detail for Gusset Plates of HSS Brace Members

(Credit: The above connection was developed by the Brian L. Cochran Associates, Inc., Consulting Structural Engineers, Los Angeles.)

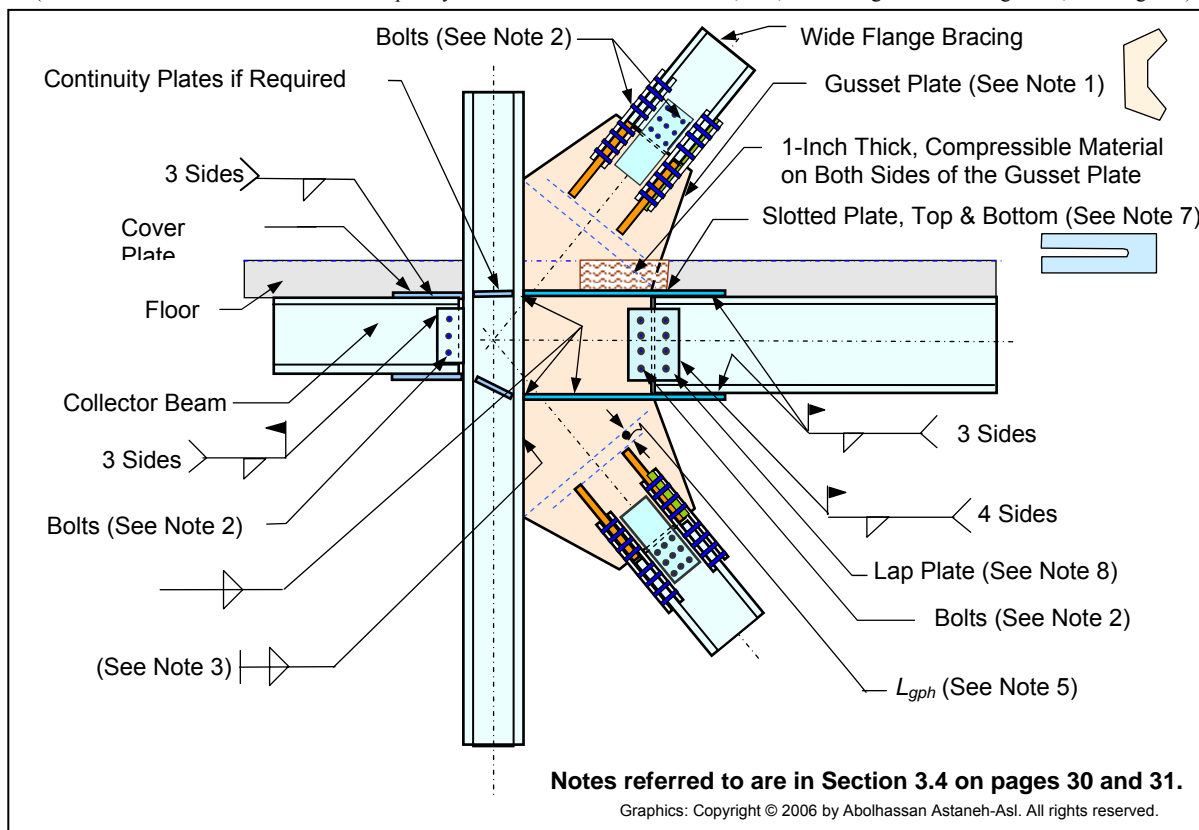

Figure 3.5. Suggested Detail for Gusset Plates of Wide Flange Brace Members

(Credit: The above detail was developed by using designs by the Cives Steel Company for the connection of the brace to the gusset and by Brian L. Cochran Associates, Inc., Consulting Structural Engineers, Los Angeles, for the rest of the detail.)

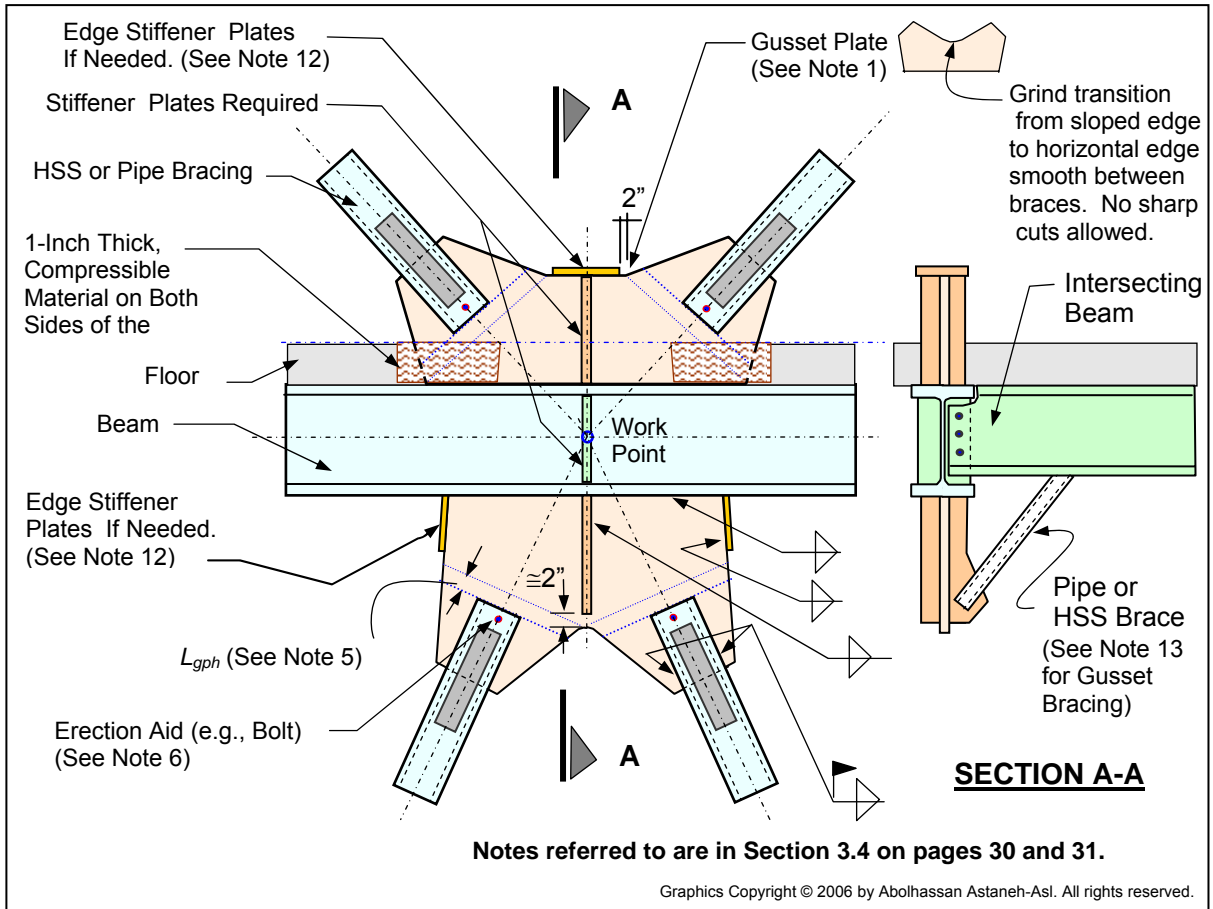

Figure 3.6. Suggested Detail for Gusset Plates of HSS Brace Members

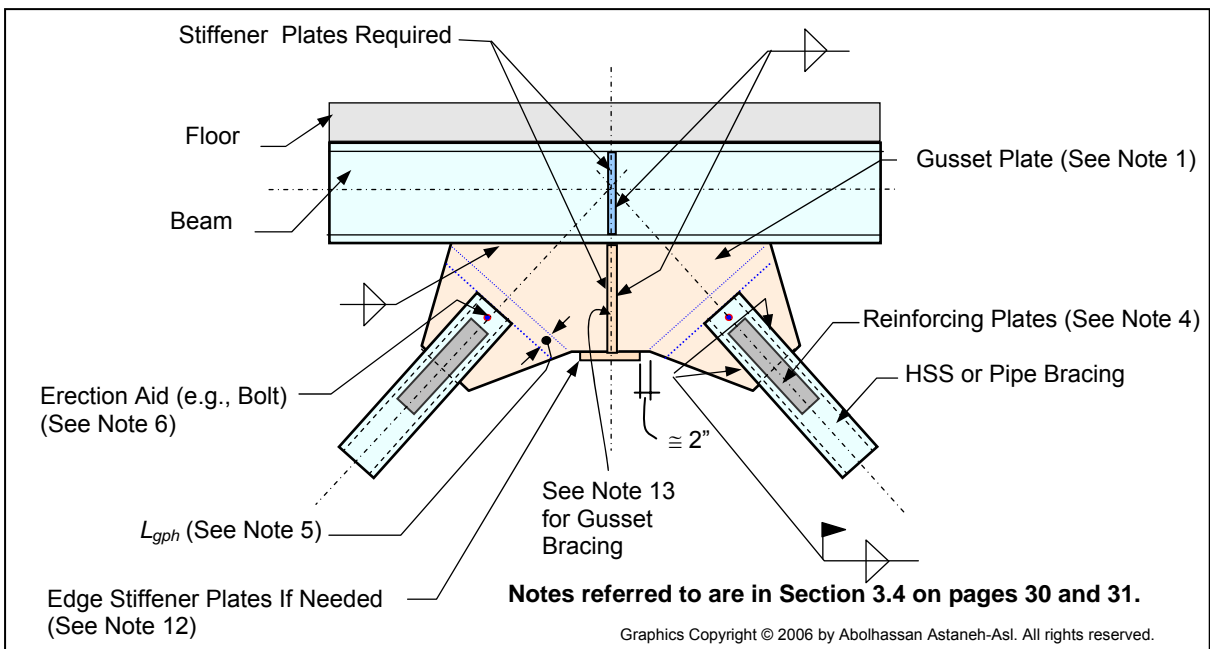

Figure 3.7. Suggested Detail for Gusset Plates of HSS Brace Members

3.6. Suggested Details for Single-Sided Gusset Plates of Special Concentrically Braced Frames

Figure 3.8 is an example of suggested details for cases where only the top or bottom gusset exists, such as in the case of roof-level gusset plates. For information not shown on the detail in the figure, the reader is referred to the two-sided connections shown in Figures 3.1 through 3.5.

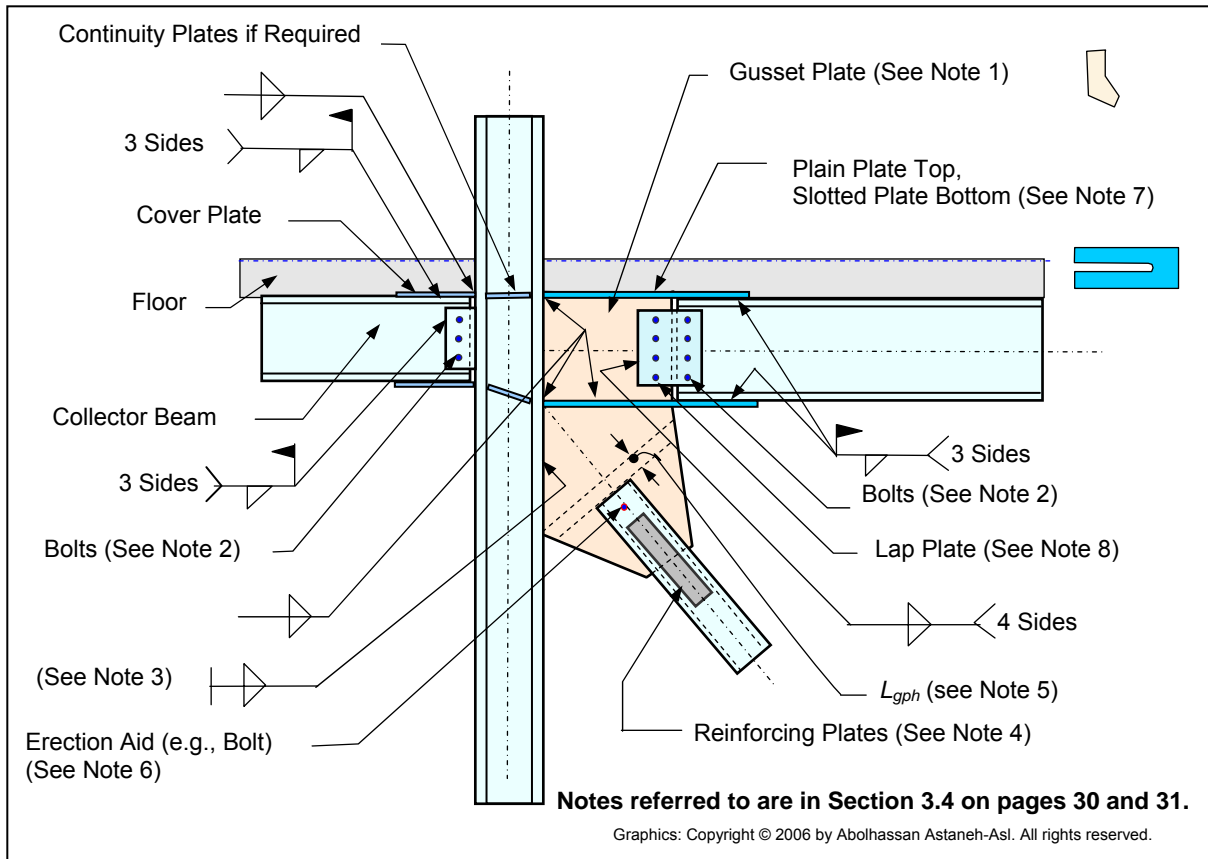

Figure 3.8 Suggested Detail for One-Sided Gusset Plates of HSS Brace Members

(Credit: The above connection was developed by the Brian L. Cochran Associates, Inc., Consulting Structural Engineers, Los Angeles.)

REFERENCES

- AISC (2005a). *Specifications for Structural Steel Buildings*. Chicago: American Institute of Steel Construction (free download at www.aisc.org).
- AISC (2005b). *Manual of Steel Construction*, 13th ed. Chicago: American Institute of Steel Construction (can be purchased at www.aisc.org).
- AISC (2005c). *Seismic Provisions for Structural Steel Buildings*. Chicago: American Institute of Steel Construction (free download at www.aisc.org).
- Astaneh-Asl, A. (1998). "Seismic Behavior and Design of Gusset Plates," in Steel Technical Information and Product Services (Steel TIPS) report. Moraga, CA: Structural Steel Educational Council (www.steeltips.org).
- Astaneh-Asl, A. (2005). "Design of Shear Tab Connections for Gravity and Seismic Loads," in Steel Technical Information and Product Services (Steel TIPS) report. Moraga, CA: Structural Steel Educational Council (www.steeltips.org).
- Astaneh-Asl, A., Goel, S. C., and Hanson, R. D. (1982). "Cyclic Behavior of Double Angle Bracing Members with End Gusset Plates," Report No. UMEE 82R7. Ann Arbor: University of Michigan.
- Astaneh-Asl, A., Goel, S. C., and Hanson, R. D. (1983). "Cyclic Behavior of Double Angle Bracing Members with Bolted Connections," *Engineering Journal*, AISC, Chicago (www.aisc.org).
- Astaneh-Asl, A., and Goel, S. C. (1984). "Cyclic In-Plane Buckling of Double Angle Bracing," *Journal of Structural Engineering*, American Society of Civil Engineers (ASCE), Vol. 110, No. 9, pp. 2036–2055 (www.asce.org).
- Astaneh-Asl, A., Goel, S. C., and Hanson, R. D. (1985). "Cyclic Out-of-Plane Buckling of Double Angle Bracing," *Journal of Structural Engineering*, ASCE, Vol. 111, No. 5, pp. 1135–1153 (www.asce.org).
- Berrens, D., and Morrison, M. (2006). Gusset Plate Details and Commentary, personal communication with the authors, PDM Strockal Inc.
- Cochran, M. L., and Honeck, W. (2004). "Special Concentric Braced Frames," Steel Technical Information and Product Services (Steel TIPS) report. Moraga, CA: Structural Steel Educational Council (www.steeltips.org).
- EPS (2006). Software to Calculate Dimensions for Gusset Plates in Special Concentrically Braced Frames, Engineering & Publishing Services (EPS), <http://www.ENGPUB.com>.
- Richardson, S., and Lindley, W. (2006). Gusset Plate Details, personal communication with the authors, W & W Steel Company, Oklahoma City.
- Sabelli, R. (2003). "Design of a Special Concentrically Braced Frame," in *SEAOC Seismic Design Manual*, Vol. III. Sacramento, CA: Structural Engineers Association of California (SEAOC).
- Sabelli, R. (2005–6). "Seismic Braced Frames: Design Concepts and Connections," *Seminar Notes*, American Institute of Steel Construction, Chicago.

Thornton, W. A. (2001). *Seismic Design of Connections in Concentrically Braced Frames*, Roswell, GA: Cives Engineering Corporation (www.cives.com).

Thornton, W. A. (2006). Gusset Plate Details and Commentary, personal communication with the authors, Cives Steel Company.

Whitmore, R. E. (1952). "Experimental Investigation of Stresses in Gusset Plates", Bulletin No. 16, Engineering Experiment Station, Univ. of Tennessee, Knoxville, May.

Winens, J. (2006). "Detailing Seismic Connections, Fabricator/Erector's Prospective," presentation at the North American Steel Construction Conference, San Antonio, TX. Chicago: American Institute of Steel Construction.

Appendix A

Other Gusset-Plate Details for SCBFs

The gusset-plate connections presented in this appendix are refined versions of some of the connections currently in use. We have attempted to introduce the $2t$ distance in these connections and detail them such that a high level of ductility, consistent with special concentric braced frames, is expected. The suggested details of the gusset-plate connections shown in Figures 3.1 through 3.5 of Chapter 3 are preferred to the connections given in this appendix for several reasons:

- A simple shop connection of one large gusset plate to the column due to the elimination of a direct beam-to-column connection.
- Uniformity of shear transfer to the column through a single gusset plate instead of plates of varying thickness (gusset plate, beam web, filler plates, shear tabs).
- Cleaner drag/collector beam connections across the beam/column/gusset plate connection through use of lap plates on the beam flanges.

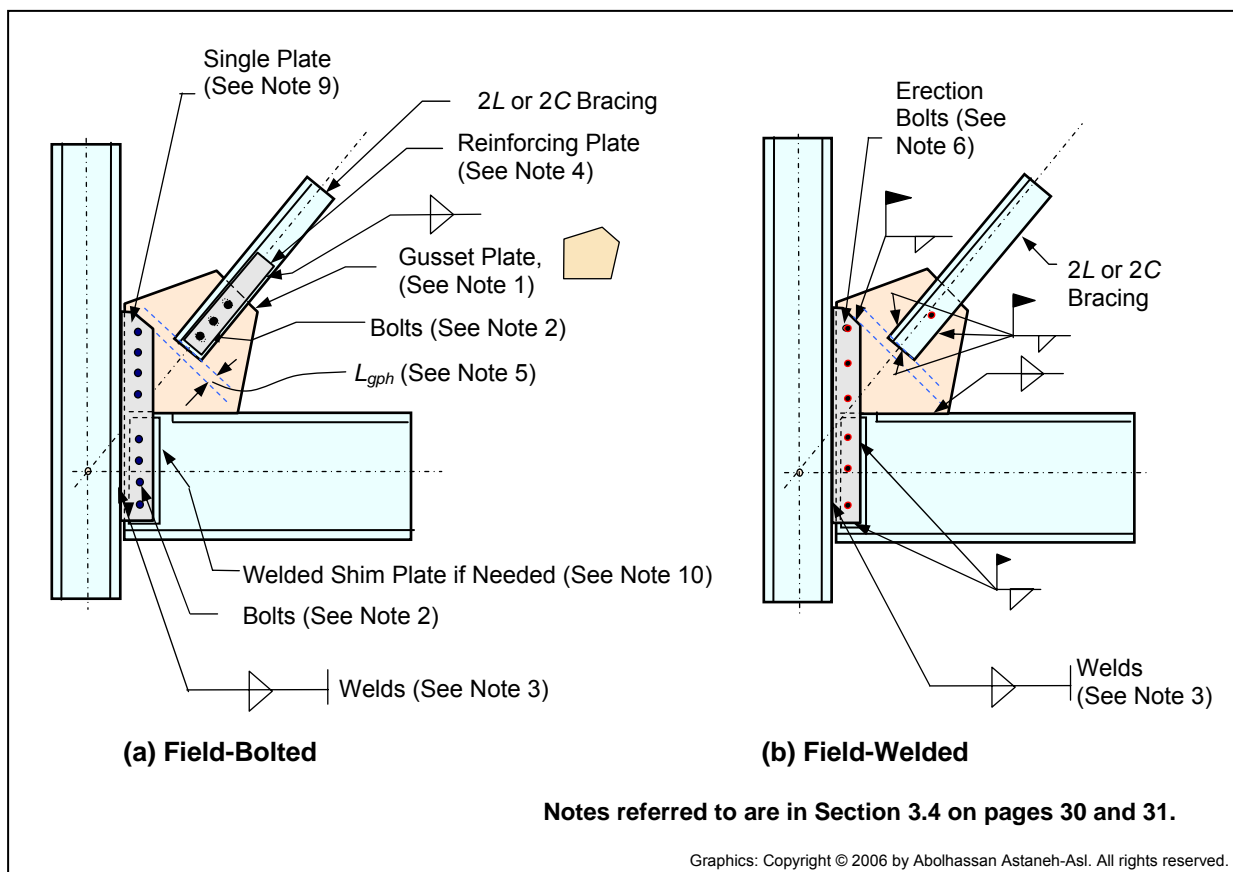

Figure A.1. Gusset-Plate Connection of Out-of-Plane Buckling Double Angle or Double Channel Brace Members

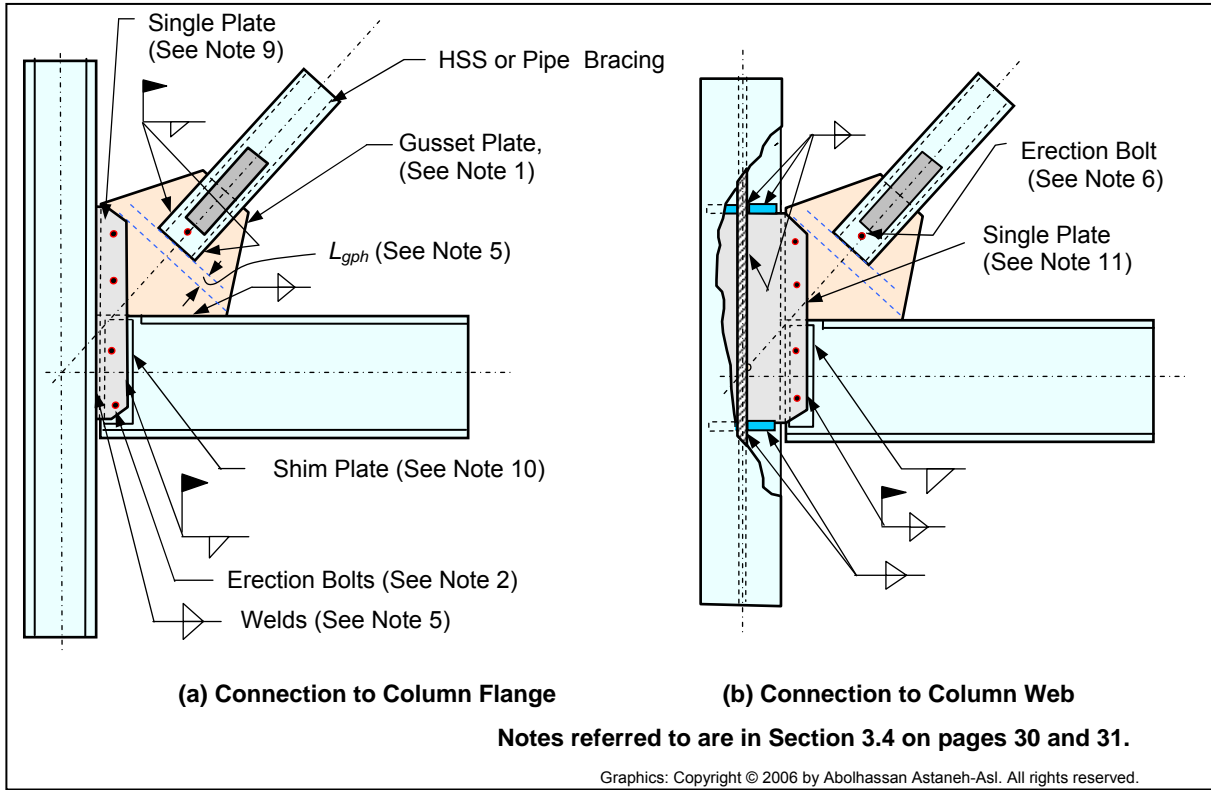

Figure A.2. All-Welded Gusset-Plate Connection of HSS Brace Member

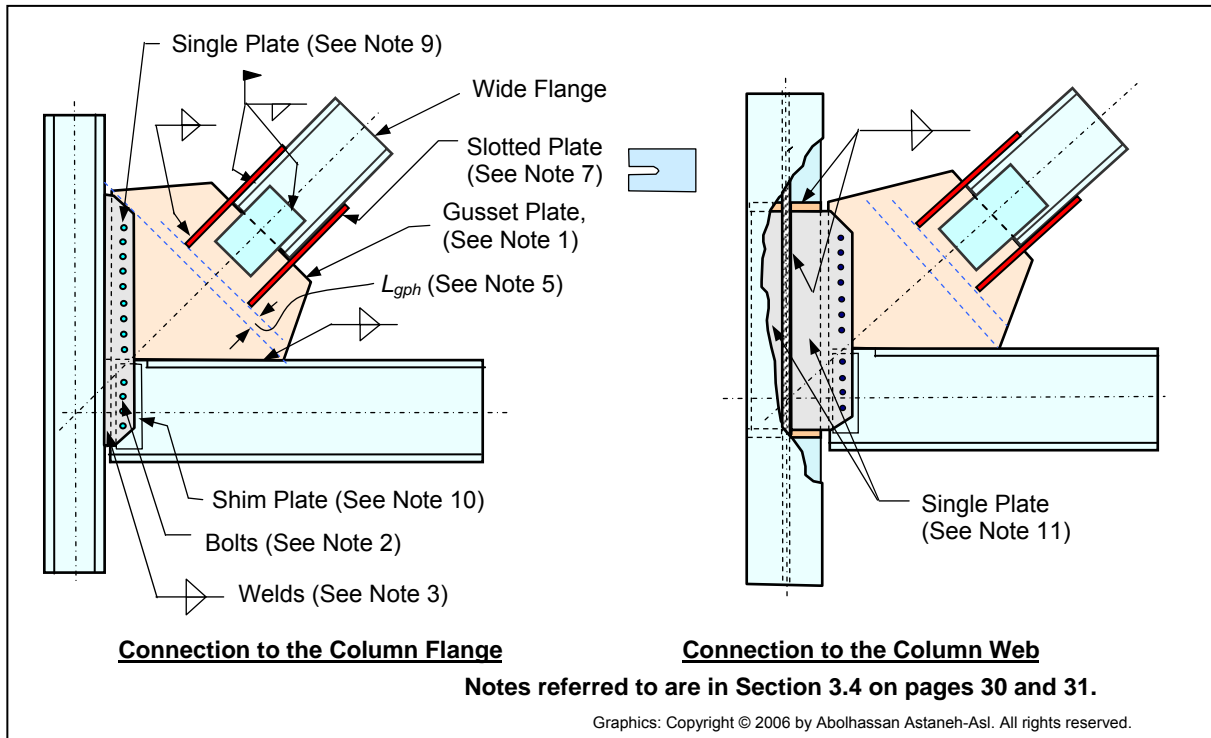

Figure A.3. All-Welded Gusset-Plate Connection of Wide Flange Brace Member

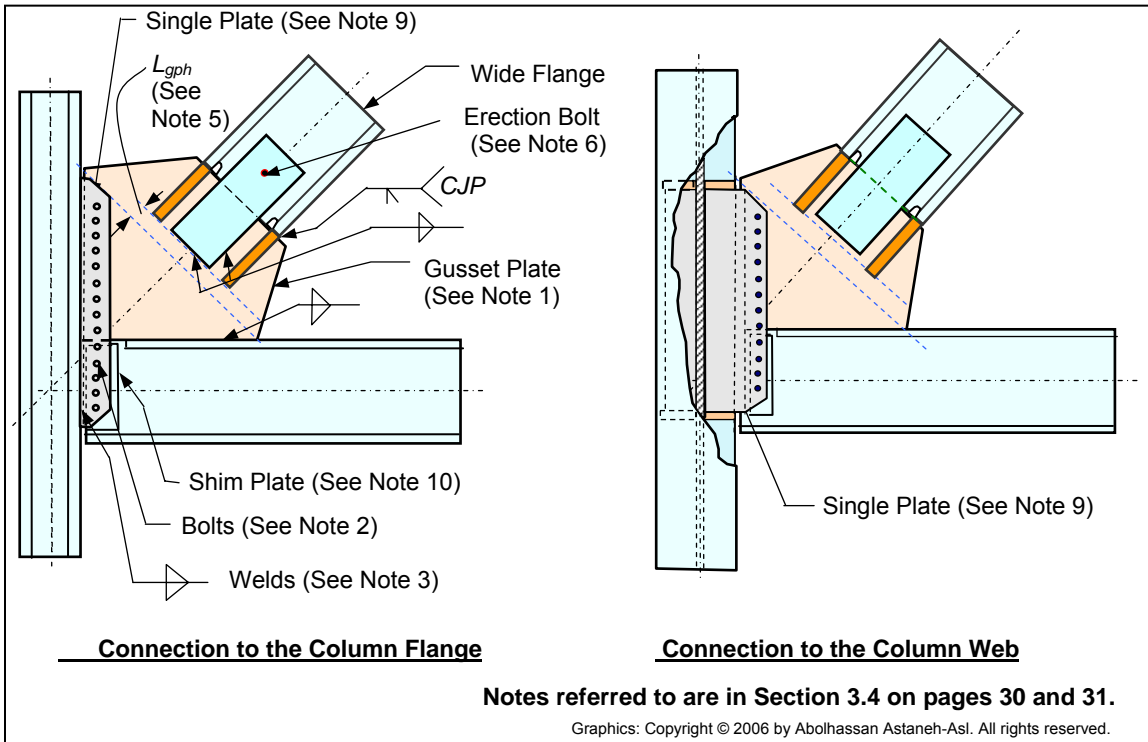

Figure A.4. All-Welded Gusset-Plate Connection of Wide Flange Brace Member

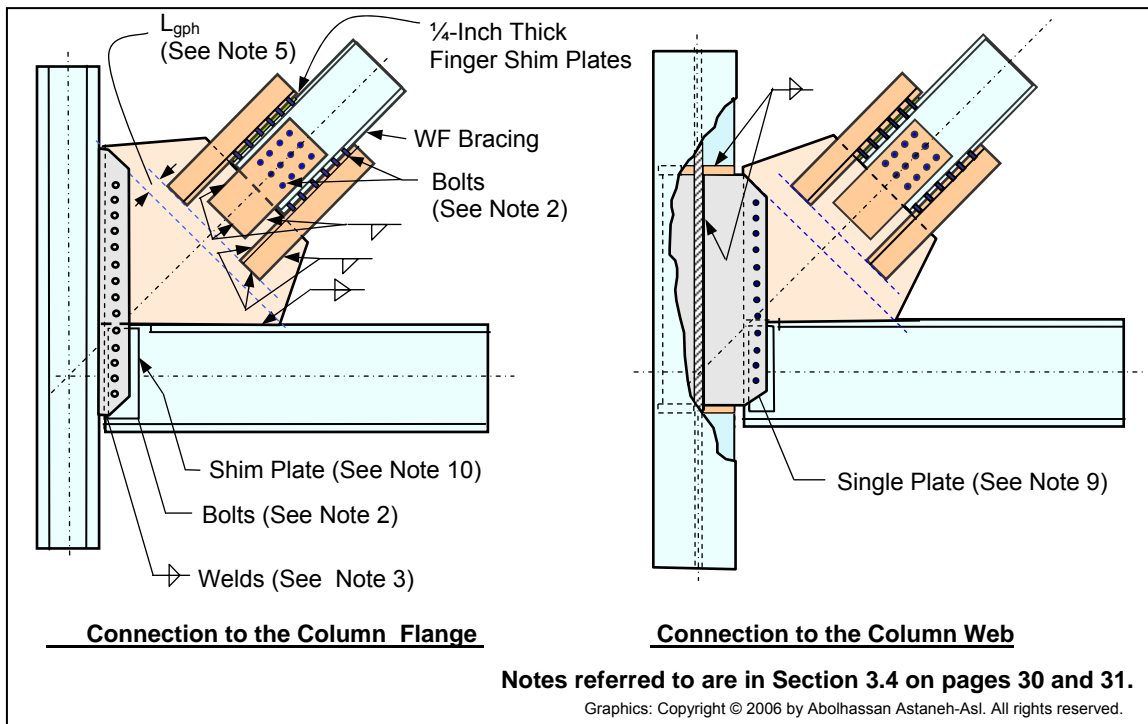

Figure A.5. Shop-Welded, Field-Bolted Gusset-Plate Connection of Wide Flange Brace Member

Appendix B

Gusset Plates with Sloped Beams

B.1. Introduction

In some cases the beam in a gusset-plate connection is sloped; such cases include roof framing, stadium-style seating, and others. Figure B.1 shows examples of connections with sloped beams. For gusset plates with horizontal beams, as discussed in Chapter 2 and shown in Figure B.2, eight dimensions are established: A , B , and L_1 through L_6 . For gusset plates with sloped beams, as shown in Figure B.3, an additional dimension, L_7 , is also needed to define the geometry of the gusset plate. The parameters used in Figures B.2 and B.3 are identical. Of course, for the sloped beam details in Figure B.3, the angle γ , which is the angle of the sloped beam (measured from horizontal), is an additional parameter to be considered. The case of the horizontal beam covered in Chapter 2 is a special case of the sloped beam covered in this appendix, but with angle γ being equal to zero. Designers should consider use of a single large gusset plate for sloped beam connections, similar to the details shown in Figures 3.1 thru 3.6. Figures B.4 and B.5 show examples of a single gusset plate used with sloped beams.

In the remainder of this appendix the direct sloped beam to column connections with the gusset plate occurring either above or below the beam are shown for ease of illustrating the gusset-plate geometry equations.

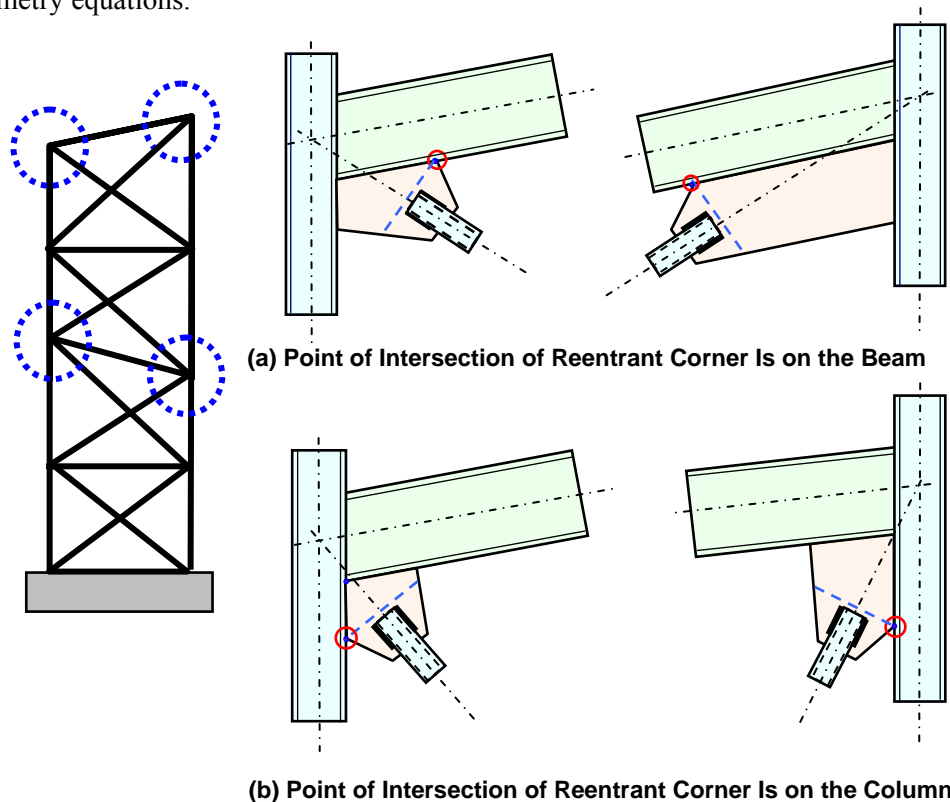

Figure B.1. Examples of Gusset-Plate Connections with Sloped Beams

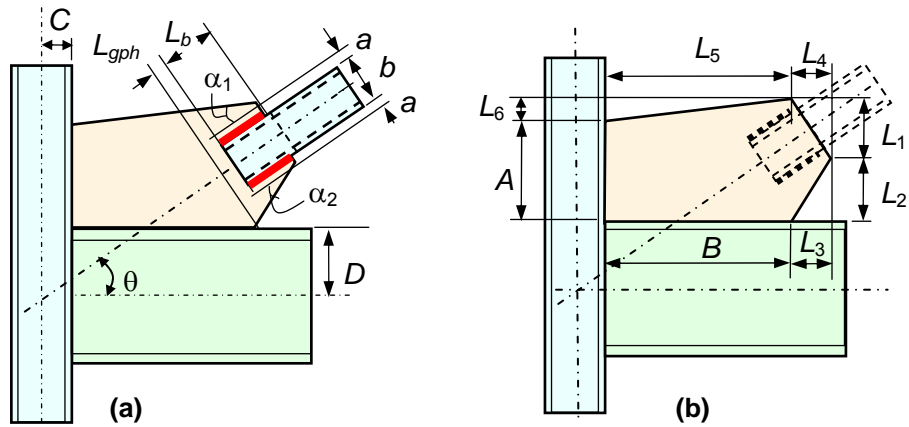

Figure B.2. Horizontal Beam:

- (a) Parameters Needed to Calculate Gusset-Plate Dimensions
- (b) Gusset-Plate Dimensions Needed for Gusset-Plate Detailing

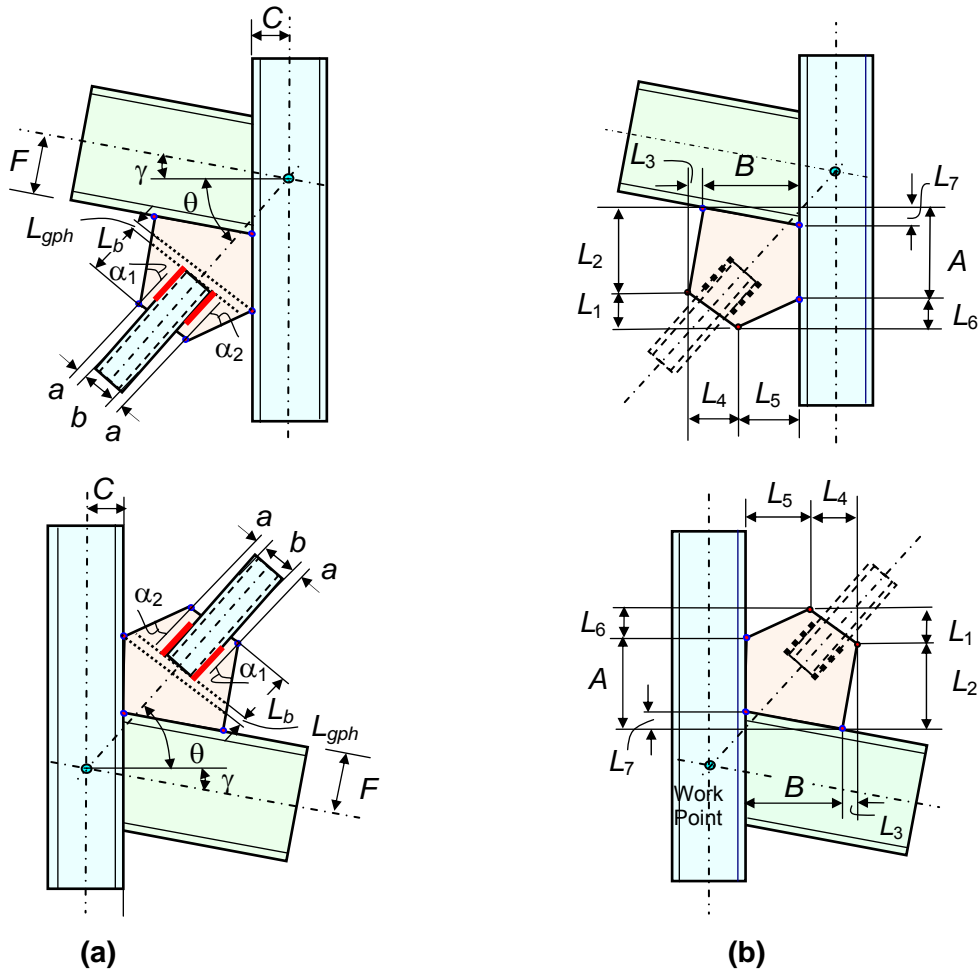

Figure B.3. Sloped Beams:

- (a) Parameters Needed to Calculate Gusset-Plate Dimensions
- (b) Gusset-Plate Dimensions Needed for Gusset-Plate Detailing

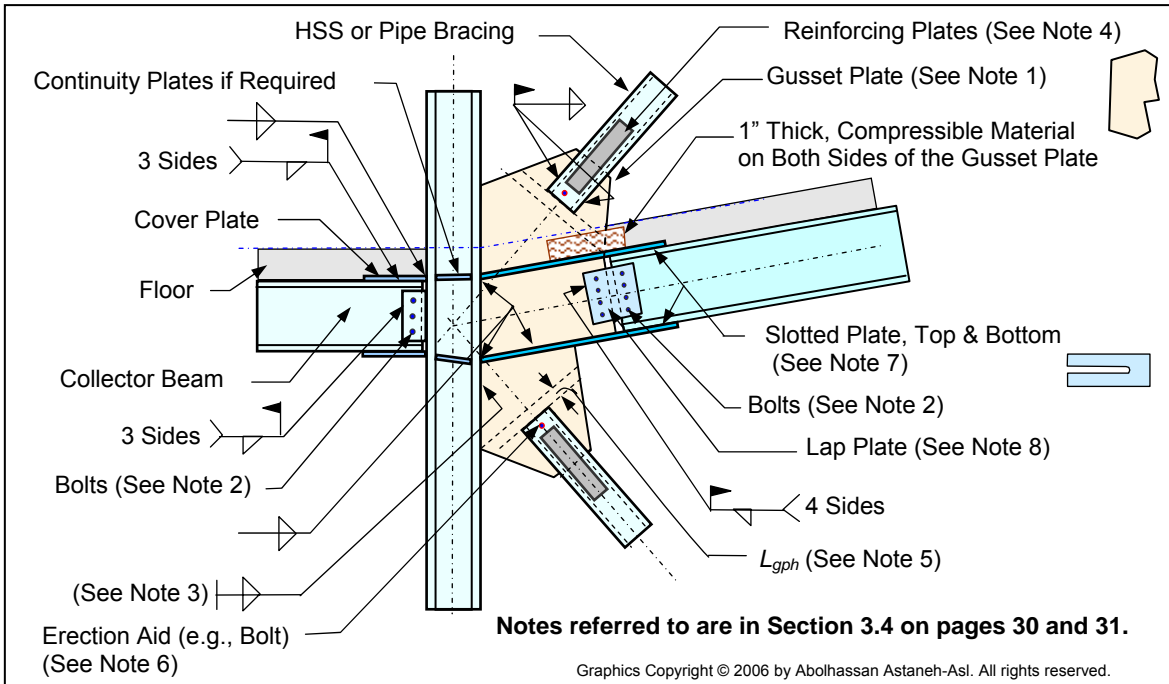

Figure B.4. Suggested Detail for Gusset Plates of HSS or Pipe Brace Members and Sloped Beam

(Credit: The above connection was developed by Brian L. Cochran Associates, Inc., Consulting Structural Engineers, Los Angeles, and is presented herein with permission.)

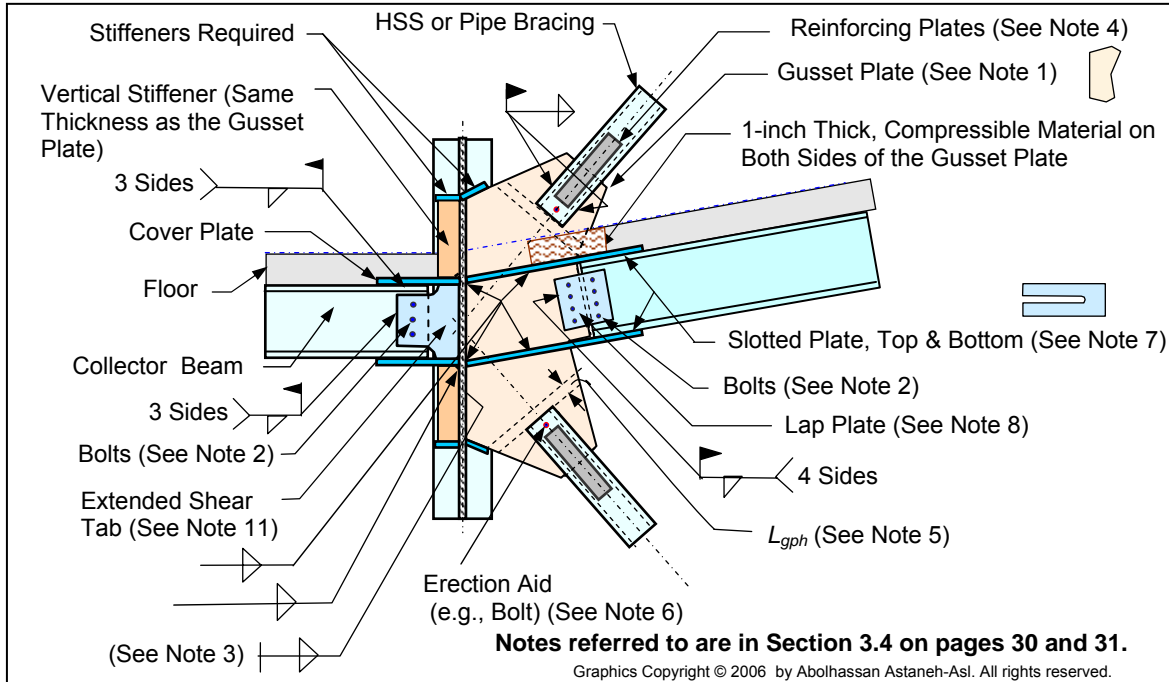

Figure B.5. Suggested Detail for Gusset Plates of HSS or Pipe Brace Members and Sloped Beam Connection to Column Web

(Credit: The above connection was developed by Brian L. Cochran Associates, Inc., Consulting Structural Engineers, Los Angeles, and is presented herein with permission.)

B.2. Establishing Gusset Dimensions for Cases with Sloped Beams

As mentioned earlier, in the case of a sloped beam there are nine gusset-plate dimensions that need to be established: A , B , and L_1 through L_7 . The first step in establishing these dimensions is to establish the location of the first reentrant corner of the gusset plate. As shown in Figures B.6 and B.7, respectively, the first reentrant corner can be either on the beam or on the column. In the following, the equations to be used for each of these two cases are provided. It should be mentioned that, like the case of the horizontal beam covered in Chapter 2, there is a special case where the two reentrant corners of the gusset define the same line of restraint.

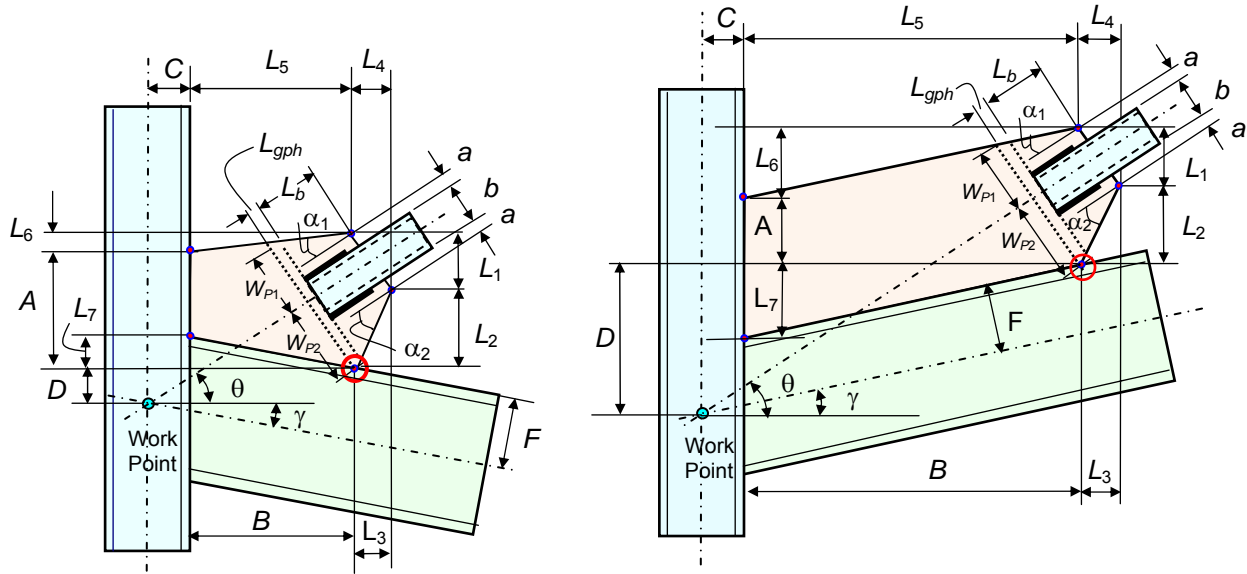

Figure B.6. Sloped Beam with Point of Intersection of the Reentrant Corner on the Beam

B.2.a. Establishing the location of the point of intersection of the first reentrant corner

To establish the location of the point of intersection of the first reentrant corner, the procedure given in Section 2.5.a of Chapter 2 can be used. In this procedure, first a parameter U given below as Equation B.1 is established.

$$U = \frac{C}{\sin(\theta)\cos(\theta)} + \frac{W_{P1}}{\cos(\theta)} - \frac{D}{\sin^2(\theta)} - \frac{W_{P2}}{\sin(\theta)\tan(\theta)} \quad (\text{B.1})$$

Where dimensions W_{P1} and W_{P2} are shown in Figures B.6 and B.7 and are given as:

$$W_{P1} = a + b/2 + (L_b + L_{gph}) \tan(\alpha_1) \quad (\text{B.2})$$

$$W_{P2} = a + b/2 + (L_b + L_{gph}) \tan(\alpha_2) \quad (\text{B.3})$$

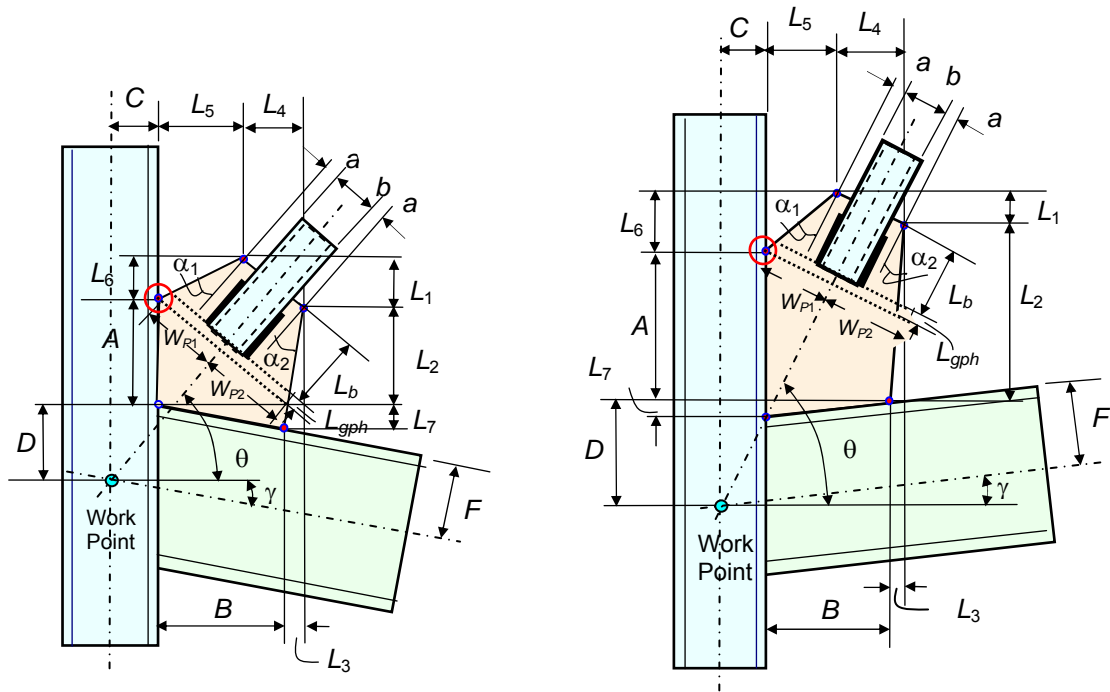

Figure B.7. Sloped Beam with Point of Intersection of the Reentrant Corner on the Column

The dimension D used in the equations and shown in Figures B.3, B.6, and B.7, is defined as the vertical distance from the “work point” to the point of intersection of the reentrant corner on the beam. In the special case of the double symmetric horizontal beam, this dimension would be half the beam depth. The value of D for the sloped beam case is given by:

$$D = \frac{\left(\frac{F}{\cos(\gamma)} \right) + \left(\frac{W_{P2} \tan(\gamma)}{\sin(\theta)} \right)}{1 - \left(\frac{\tan(\gamma)}{\tan(\theta)} \right)} \quad (\text{B.4})$$

In Equation B.4, referring to Figures B.6 and B.7, angle γ should be entered positive if the angle between the beam and column is less than 90 degrees and negative if the angle between the beam and column is greater than 90 degrees.

After establishing the value of U using Equation B.1, the following conditions will establish the location of the first reentrant corner (that is, the intersection of the restraint line):

- (1) If $U > 0$ the point of intersection of the restraint line is on the column
- (2) If $U < 0$ the point of intersection of the restraint line is on the beam; and
- (3) If $U = 0$ the point of intersection of the restraint line is occurring simultaneously both on the column and on the beam flange

B.2.b. Establishing gusset dimensions A , B , and L_1 to L_7 when the restraint line point of intersection (the first reentrant corner) is on the beam

Referring to Figure B.6, the following relationships can be established among various dimensions of the gusset-plate geometry when the intersection of the restraint line is on the beam and the beam is sloped. The equations for A , B , and L_1 to L_6 are the same as were given in Chapter 2. The equation for L_7 , Equation 2.19a, is new and is needed for cases of gusset plates with sloped beams. For gusset plates with horizontal beams, both angle γ and L_7 are equal to zero.

The following equations from Chapter 2 for the gusset-plate dimensions can be programmed into a spreadsheet to calculate the gusset-plate dimensions automatically. One such spreadsheet has been developed by the first author, A. Astaneh-Asl, and is offered by Engineering & Publishing Services (EPS). For more information on this spreadsheet and how to obtain a copy, the interested reader is referred to the EPS web site, <http://www.ENGPUB.com>.

$$L_1 = (2a + b) \cos(\theta) \quad (2.12)$$

$$L_2 = \left(\frac{L_{gph} + L_b}{\cos(\alpha_2)} \right) \sin(\theta + \alpha_2) \quad (2.13)$$

$$L_3 = \frac{L_2}{\tan(\theta + \alpha_2)} \quad (2.14)$$

$$B = \frac{D}{\tan(\theta)} + \frac{W_{P2}}{\sin(\theta)} - C \quad (2.15)$$

$$L_4 = (2a + b) \sin(\theta) \quad (2.16)$$

$$L_5 = B + L_3 - L_4 \quad (2.17)$$

$$L_6 = L_5 \tan(\theta - \alpha_1) \quad (2.18)$$

$$A = L_1 + L_2 - L_6 \quad (2.19)$$

$$L_7 = B \tan(\gamma) \quad (2.19a)$$

The value of D in the preceding equations should be the value defined by Equation B.4 above.

Figure B.8 shows examples of gusset-plate geometries resulting from using the preceding equations.

B.2.c. Establishing gusset dimensions A , B , and L_1 to L_7 when the restraint line point of intersection (the first reentrant corner) is on the column

Referring to Figure B.7, the following relationships, which are the same as established in Chapter 2, can be established among the various dimensions of the gusset-plate geometry. Again, the equations for A , B , and L_1 to L_6 are the same as were given in Chapter 2. The following equation for L_7 , Equation 2.19a, is new and is needed for cases of gusset plates with sloped beams.

$$L_6 = [(L_{gph} + L_b) / \cos(\alpha_1)] \sin(\theta - \alpha_1) \quad (2.20)$$

$$L_5 = [(L_{gph} + L_b) / \cos(\alpha_1)] \cos(\theta - \alpha_1) \quad (2.21)$$

$$L_4 = (2a + b) \sin(\theta) \quad (2.22)$$

$$A = C \tan(\theta) + \frac{W_{P1}}{\cos(\theta)} - D \quad (2.23)$$

$$L_1 = (2a + b) \cos(\theta) \quad (2.24)$$

$$L_2 = A + L_6 - L_1 \quad (2.25)$$

$$L_3 = L_2 \tan(90^\circ - \theta - \alpha_2) \quad (2.26)$$

$$B = L_4 + L_5 - L_3 \quad (2.27)$$

$$L_7 = B \tan(\gamma) \quad (2.19a)$$

Figure B.8 shows examples of gusset-plate geometries resulting from using the preceding equations.

B.2.d. Establishing gusset dimensions A , B , and L_1 to L_7 when the restraint line point of intersection (the first reentrant corner) is on the column as well as on the beam

For this special case, the intersection of the restraint line is both on the beam as well as on the column. For this special case, either set of the preceding equations for intersection on the beam or on the column can be used. Identical designs will result.

A spreadsheet developed by the first author, A. Astaneh-Asl, can be used to establish dimensions of the gusset plates at the base of columns. For more information on this spreadsheet and how to obtain a copy, the interested reader is referred to the EPS web site, <http://www.ENG PUB.com>.

B.3 Gusset Dimensions for Braces Intersecting a Sloping Beam from Below

The gusset-plate dimensions derived in section B.2 for sloped beams were illustrated for braces framing to the top side of the beam. Where brace members frame to the underside of the sloping beam (Figures B.1[b] and B.3) the same design equations can still be used. The connection detail of a brace member framing to the underside of the sloped beam is simply the mirror image (reflected across a horizontal line) of the details illustrated in Figures B.6 and B.7.

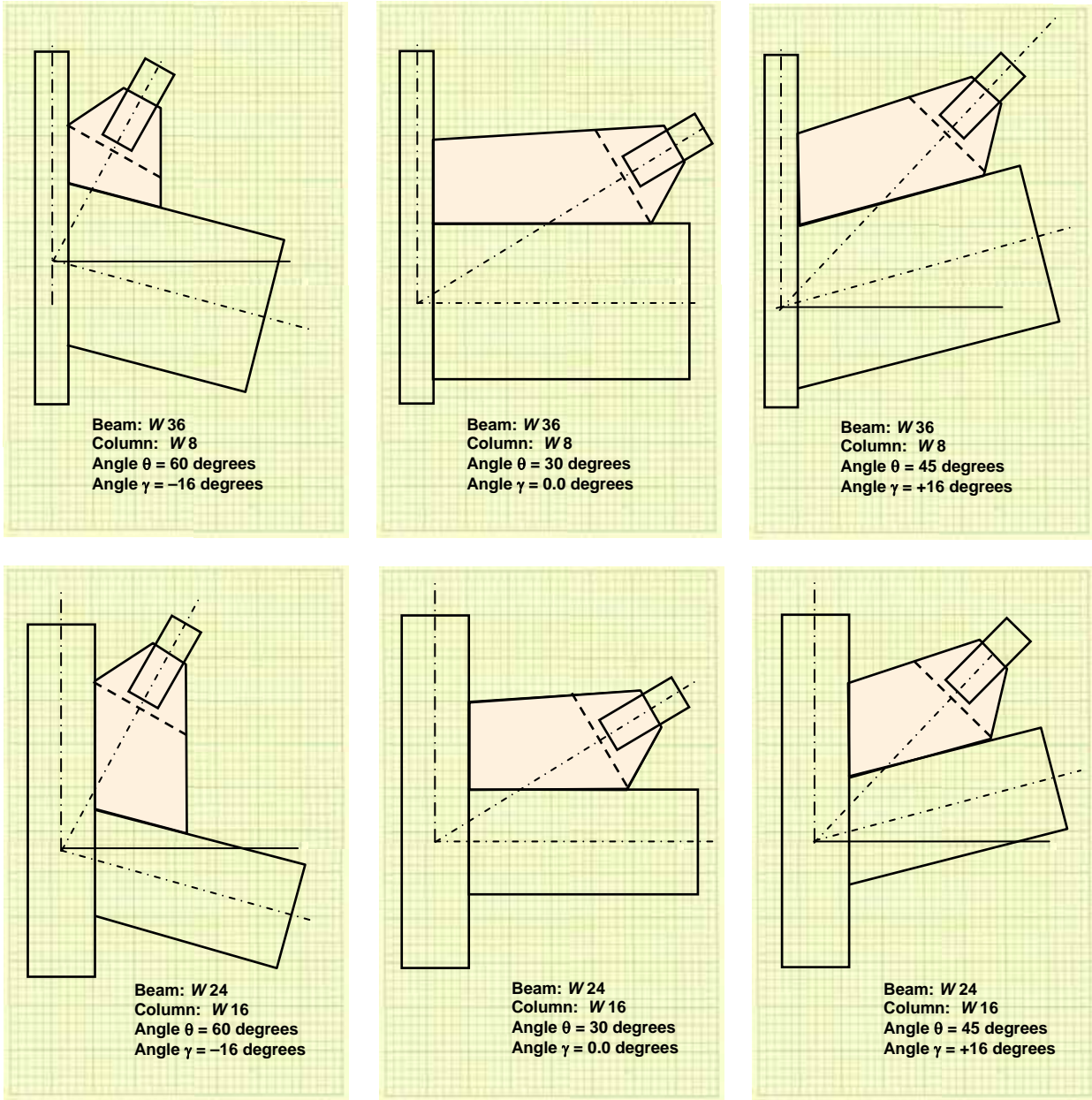

Figure B.8. Examples of Gusset Plates Resulting from Equations in the Text

Appendix C

Gusset Plates at the Base of Columns

C.1. Introduction

In a typical braced frame, the lowest braced member is connected to the base of the boundary column where the column is supported on the base plate as shown in Figure C.1. This “gusset-to-base plate” detail is the subject of this appendix.

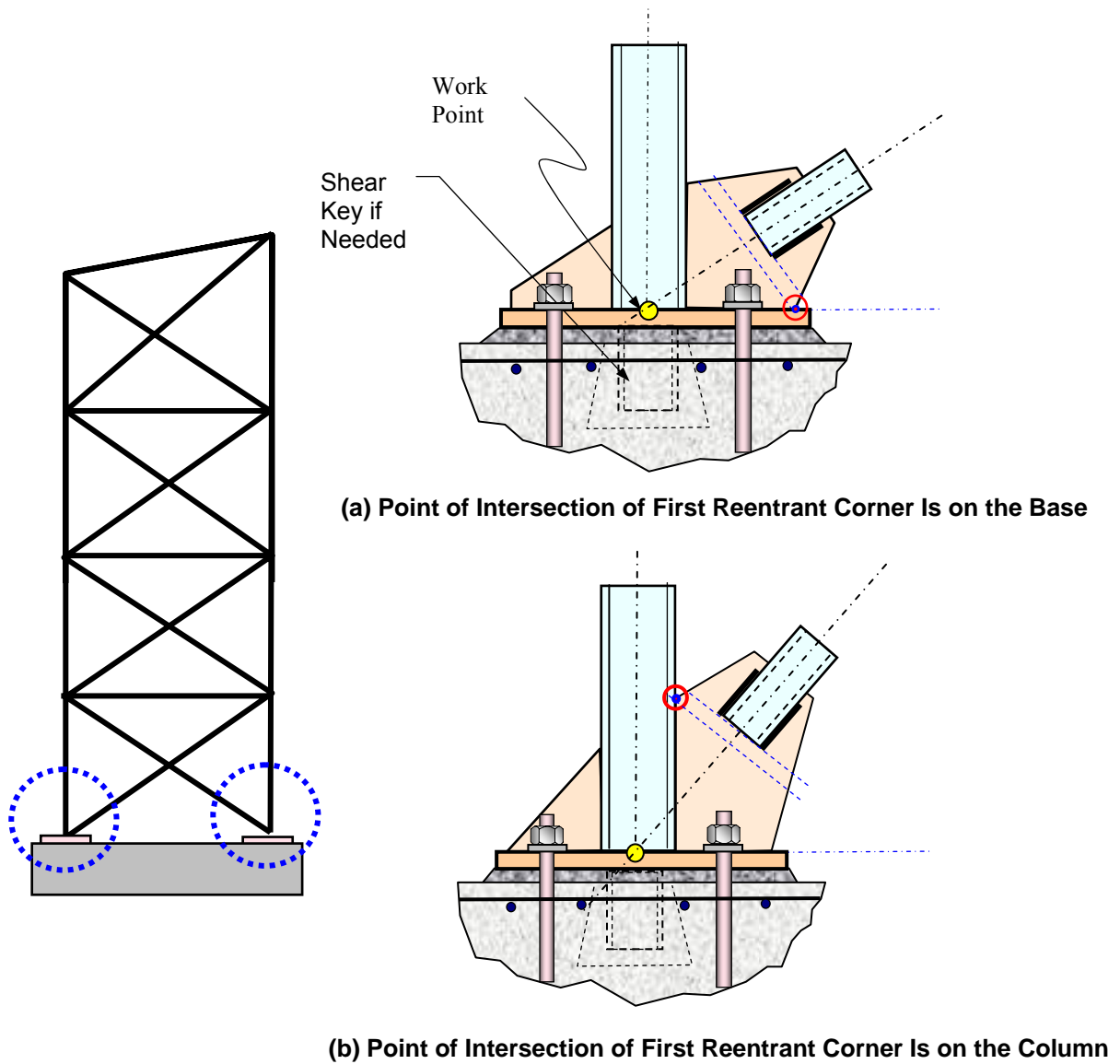

Figure C.1. Examples of Gusset-Plate Connections at the Base of Columns

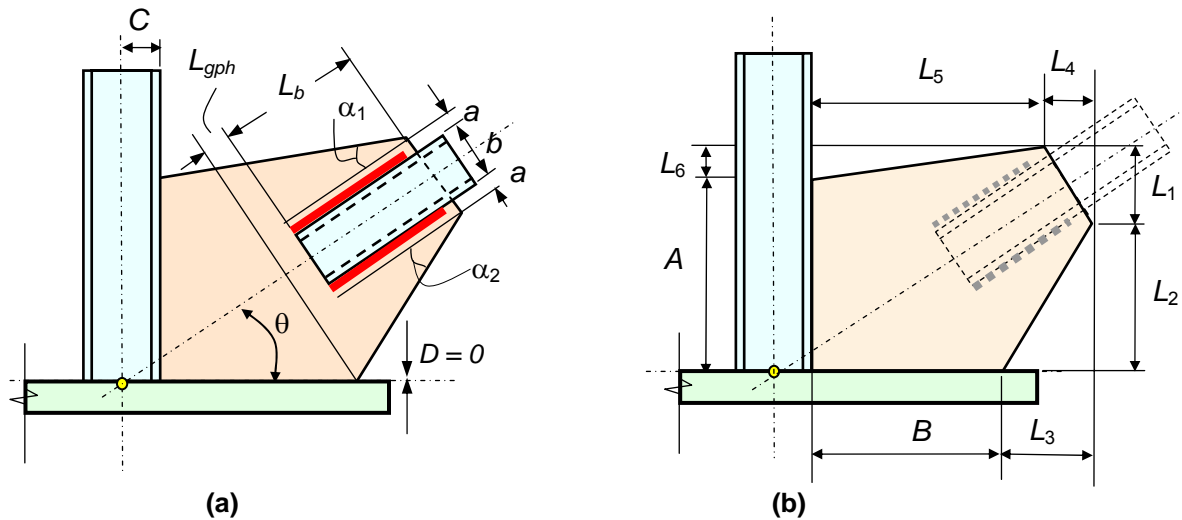

Figure C.2. Gusset Plate to Base Plate Connection:
 (a) Nine Parameters Needed to Calculate Eight Gusset-Plate Dimensions
 (b) Eight Gusset-Plate Dimensions Needed for Gusset-Plate Detailing

C.2. Establishing Gusset Dimensions for Gussets at the Base of Columns

Figure C.2 shows a typical gusset plate at the base of a column in a special concentrically braced frame (SCBF). Figure C.2 (a) shows the nine parameters needed to establish the eight gusset-plate dimensions A , B , and L_1 through L_6 shown in Figure C.2 (b).

The equations that are needed to establish the gusset-plate dimensions are exactly the same as given in Chapter 2. Notice that for the case of gusset plates at the base of columns, the dimension D in the equations should be entered as zero since the work point is assumed to be on the top surface of the base plate.

As was discussed in Chapter 2, the first step in establishing the gusset-plate dimensions is to establish the location of the point of intersection of the reentrant corner of the gusset plate. As shown in Figures C.1(a) and C.1(b), respectively, the reentrant corner can intersect the base plate or the column. If the reentrant corner intersects the base plate, Equations 2.12 through 2.19 given in Chapter 2 should be used, and if the intersection point is on the column, Equations 2.20 through 2.27 given in Chapter 2 will be applicable. If in special cases the first line of restraint intersects both the base plate and the column, either set of equations can be used.

C.3 Topping Slabs and Hinge Zones at Base-Plate Connections

Typically the column base plate is located below the finish floor (top of slab) and consideration needs to be given as to how the confinement in concrete will restrain the gusset plate from forming a hinge on the assumed restraint line. As was shown in Chapter 3 for the gusset plate to beam connection with a slab present, the gusset plate can also be isolated from the ground-floor slab to allow the first line of restraint to extend to the base plate. Figure C.3(a) shows a gusset-

plate restraint line that extends below the slab-on-grade and thus needs to be isolated from the slab for the gusset plate to perform properly. This restraint line is typically defined by the gusset reentrant corner at the base plate.

Figure C.3(b) shows a gusset-plate restraint line that occurs above the elevation of the finish slab. This second case may be treated identically with the case of a horizontal beam addressed in Chapter 2, with the dimension D (the beam half-depth) equal to the thickness of the slab above the work point, as shown in the figure. This restraint line may be defined by the gusset reentrant corner at the slab surface, at the column, or by both, as discussed in Chapter 2.

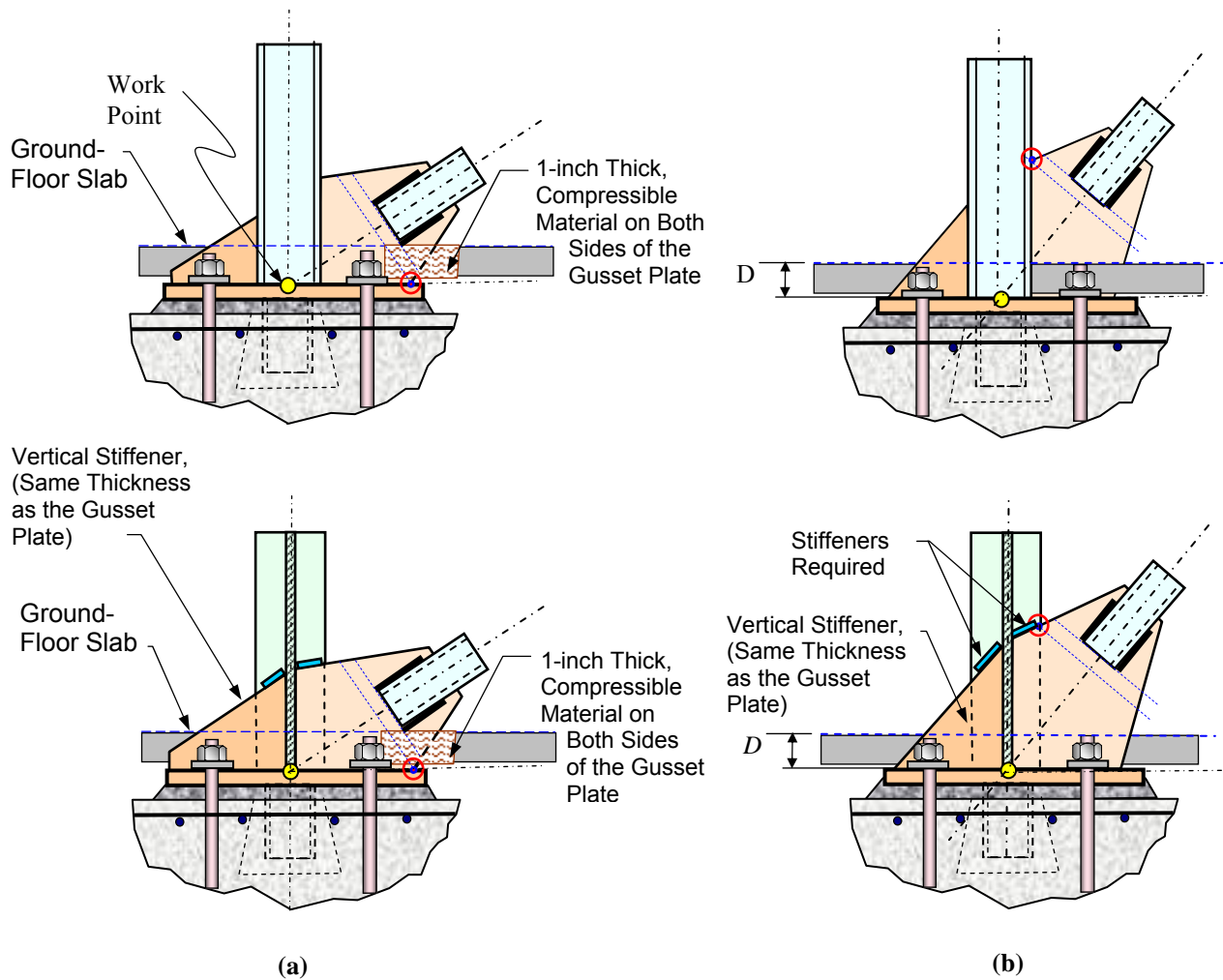

Graphics Copyright © 2006 by Abolhassan Astaneh-Asl. All rights reserved.

Figure C.3: Topping Slabs and Hinge Zones at Base-Plate Connections

- (a) Gusset-Plate First Restraint Line Extends below the Surface of the Slab
- (b) Gusset-Plate First Restraint Line above the Slab

About the Authors:



Abolhassan Astaneh-Asl, Ph.D., P.E., is a professor of structural engineering at the University of California Berkeley and a faculty researcher at the multidisciplinary Center for Catastrophic Risk Management (www.ccrm.berkeley.edu). He is the winner of the 1998 T. R. Higgins Lectureship Award of the American Institute of Steel Construction (AISC). Since 1968, he has been involved in design, teaching, and research on steel and composite structures of buildings and bridges. In the aftermath of the September 11, 2001, tragic terrorist attacks on the World Trade Center, he conducted a “Reconnaissance and Perishable Data Collection” project in New York, funded by the National Science Foundation, on the collapsed towers of the World Trade Center, and in 2002 he testified on his findings before the Committee on Science of the U.S. House of Representatives.

He can be reached at:
781 Davis Hall, Univ. of Calif.
Berkeley, CA 94720-1710
Phone and Fax: (925) 946-0903
E-mail: Astaneh@ce.berkeley.edu
Web: www.astaneh.net and
www.ce.berkeley.edu/~astaneh



Michael Cochran, S.E., is vice president of Brian L. Cochran Associates, Inc., in Los Angeles, California. He is a member of Building Seismic Safety Council (BSSC) TS-6 and the American Institute of Steel Construction (AISC) Connection Prequalification Review Panel (CPRP). He is a coauthor of the Steel TIPS for special concentrically braced frames (SCBFs) and a past speaker on the design of special and ordinary concentrically braced frames (SCBFs and OCBFs) for AISC and the Structural Engineers Association of Southern California (SEAOSC). He has been involved in the design of both new buildings and seismic retrofit of existing buildings typically in the range of one to ten stories.

He can be reached at:
Brian L Cochran Associates, Inc.
Consulting Structural Engineers
2036 Armacost Avenue
Los Angeles, CA 90025
Phone: 310-207-6638
E-mail: MLCSE@aol.com



Rafael Sabelli, S.E., is a principal of DASSE Design in San Francisco. He is a member of the Task Committee on the Seismic Provisions for Structural Steel Buildings of the American Institute of Steel Construction (AISC) and is the author of numerous publications on concentrically braced frames including analytical studies and design guides on buckling-restrained braced frames. He was the 2000 National Earthquake Hazards Reduction Program (NEHRP) Professional Fellow in Earthquake Hazard Reduction and is the past chair of the Seismology Committee of the Structural Engineers Association of California (SEAOC).

He can be reached at:
DASSE Design Inc.
33 New Montgomery, Suite 850
San Francisco, CA 94105

**Steel Technical Information and Product Services (Steel TIPS) reports
available at <http://www.steeltips.org>**

- Dec. 06: Seismic Detailing of Gusset Plates for Special Concentrically Braced Frames, by Abolhassan Astaneh-Asl, Michael L. Cochran, and Rafael Sabelli
- Aug. 06: Alfred Zampa Memorial Steel Suspension Bridge, by Alfred Mangus and Sarah Picker
- July 06: Buckling and Fracture of Concentric Braces Under Inelastic Loading, by B. Fell, A. Kanvinde, G. Deierlein, A. Myers, and X. Fu
- Sept. 05: Notes on Design of Double-Angle and Tee Shear Connections for Gravity and Seismic Loads, by Abolhassan Astaneh-Asl
- June 05: Design of Shear Tabs for Gravity and Seismic Loads, by Abolhassan Astaneh-Asl
- Apr. 05: Limiting Net Section Fracture in Slotted Tube Braces, by Frances Yang and Stephen Mahin
- July 04: Buckling Restrained Braced Frames, by Walterio A. Lopez and Rafael Sabelli.
- May 04: Special Concentric Braced Frames, by Michael Cochran and William Honeck.
- Dec. 03: Steel Construction in the New Millennium, by Patrick M. Hassett.
- Aug. 02: Cost Consideration for Steel Moment Frame Connections, by Patrick M. Hassett and James J. Putkey.
- June 02: Use of Deep Columns in Special Steel Moment Frames, by Jay Shen, Abolhassan Astaneh-Asl, and David McCallen.
- May 02: Seismic Behavior and Design of Composite Steel Plate Shear Walls, by Abolhassan Astaneh-Asl.
- Sept. 01: Notes on Design of Steel Parking Structures Including Seismic Effects, by Lanny J. Flynn and Abolhassan Astaneh-Asl.
- June 01: Metal Roof Construction on Large Warehouses or Distribution Centers, by John L. Mayo.
- Mar. 01: Large Seismic Steel Beam-to-Column Connections, by Egor P. Popov and Shakhzod M. Takhirov.
- Jan. 01: Seismic Behavior and Design of Steel Shear Walls, by Abolhassan Astaneh-Asl.
- Oct. 99: Welded Moment Frame Connections with Minimal Residual Stress, by Alvaro L. Collin and James J. Putkey.
- Aug. 99: Design of Reduced Beam Section (RBS) Moment Frame Connections, by Kevin S. Moore, James O. Malley, and Michael D. Engelhardt.
- July 99: Practical Design and Detailing of Steel Column Base Plates, by William C. Honeck and Derek Westphal.
- Dec. 98: Seismic Behavior and Design of Gusset Plates, by Abolhassan Astaneh-Asl.
- Mar. 98: Compatibility of Mixed Weld Metal, by Alvaro L. Collin & James J. Putkey.
- Aug. 97: Dynamic Tension Tests of Simulated Moment Resisting Frame Weld Joints, by Eric J. Kaufmann.
- Apr. 97: Seismic Design of Steel Column-Tree Moment-Resisting Frames, by Abolhassan Astaneh-Asl.
- Jan. 97: Reference Guide for Structural Steel Welding Practices.
- Dec. 96: Seismic Design Practice for Eccentrically Braced Frames (Based on the 1994 UBC), by Roy Becker and Michael Ishler.
- Nov. 95: Seismic Design of Special Concentrically Braced Steel Frames, by Roy Becker.
- July 95: Seismic Design of Bolted Steel Moment-Resisting Frames, by Abolhassan Astaneh-Asl.
- Apr. 95: Structural Details to Increase Ductility of Connections, by Omer W. Blodgett.
- Dec. 94: Use of Steel in the Seismic Retrofit of Historic Oakland City Hall, by William Honeck and Mason Walters.
- Dec. 93: Common Steel Erection Problems and Suggested Solutions, by James J. Putkey.
- Oct. 93: Heavy Structural Shapes in Tension Applications.
- Mar. 93: Structural Steel Construction in the '90s, by F. Robert Preece and Alvaro L. Collin.
- Aug. 92: Value Engineering and Steel Economy, by David T. Ricker.
- Oct. 92: Economical Use of Cambered Steel Beams.
- July 92: Slotted Bolted Connection Energy Dissipaters, by Carl E. Grigorian, Tzong-Shuoh Yang and Egor P. Popov.
- June 92: What Design Engineers Can Do to Reduce Fabrication Costs, by Bill Dyker and John D. Smith.
- Apr. 92: Designing for Cost Efficient Fabrication, by W. A. Thornton.
- Jan. 92: Steel Deck Construction.
- Sept. 91: Design Practice to Prevent Floor Vibrations, by Farzad Naeim.
- Mar. 91: LRFD-Composite Beam Design with Metal Deck, by Ron Vogel.
- Dec. 90: Design of Single Plate Shear Connections, by Abolhassan Astaneh-Asl, Steven M. Call and Kurt M. McMullin.
- Nov. 90: Design of Small Base Plates for Wide Flange Columns, by W. A. Thornton.
- May 89: The Economies of LRFD in Composite Floor Beams, by Mark C. Zahn.
- Jan. 87: Composite Beam Design with Metal Deck.
- Feb. 86: UN Fire Protected Exposed Steel Parking Structures.
- Sept. 85: Fireproofing Open-Web Joists and Girders.
- Nov. 76: Steel High-Rise Building Fire.

STRUCTURAL STEEL EDUCATIONAL COUNCIL

**Funding provided by the California Field Iron Workers Administrative Trust
A Union Trust Fund**

**P.O. Box 6190
Moraga, CA 94570
Tel. (925) 631-1313
Fax. (925) 631-1112
Fred Boettler, Administrator**

Steel TIPS may be viewed and downloaded at www.steeltips.org

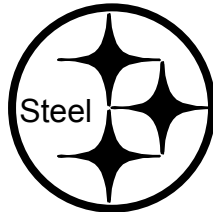

Participating Members of SSEC

ABOLHASSAN ASTANEH-ASL, Ph.D., P.E.; UNIVERSITY OF CALIFORNIA, BERKELEY

FRED BREISMEISTER, P.E.; STROCAL, INC.

MICHAEL COCHRAN, S.E.; BRIAN L. COCHRAN ASSOCIATES

RICH DENIO; KPFF CONSULTING ENGINEERS

JEFFREY EANDI, P.E.; EANDI METAL WORKS, INC.

PATRICK M. HASSETT, S.E.; HASSETT ENGINEERING, INC.

JOHN KONECHNE, P.E.; CALIFORNIA ERECTORS, INC.

WALTERIO LOPEZ, S.E.; RUTHERFORD/CHEKENE

BRETT MANNING, S.E.

LARRY MCLEAN; MCLEAN STEEL, INC.

KEVIN MOORE; CETUS CONSULTING INC.

JAY MURPHY; MURPHY PACIFIC CORPORATION

RICHARD PERSONS; U.S. STEEL

JAMES J. PUTKEY, P.E.; CONSULTING CIVIL ENGINEER

STEVE THOMPSON; SME STEEL CONTRACTORS